

Stephens Park Stream Bank Restoration Project

Vail, CO

Colorado Water Conservation Board – Healthy Rivers Fund Grant Final Report

DRAFT - April 1, 2012

I. PROJECT SUMMARY

The reach of Gore Creek flowing through the Town of Vail has been subjected to numerous disturbances over the past 30 years (the past 6 years the Town has seen unprecedented development) that has led to increased encroachment into the public stream tract, excessive snow removal, snow dumping and use of traction sand and cinders, lack of proper stormwater pollution prevention and best management practices (BMPs), improper fishing, erosion and lack of education has led to increasingly impaired conditions in Gore Creek, and ultimately, the Eagle River. In 2010, Town of Vail completed the Gore Creek Stormwater Pollution Prevention Plan, identifying necessary measures to improve the health of Gore Creek and lessen the impact of development. Throughout the planning process, a group of concerned citizens and fly fisherman, Town of Vail environmental staff, and the Eagle River Watershed Council began to recognize and document their concerns over the decreasing fish and insect population and negative impacts of urban development and improper practices in Town. Erosion and negative impacts from high use was noted at Stephens Park, in West Vail. Since then, the Gore Creek Restoration Task Force (GCR Task Force) has been formed. Members began a volunteer effort to perform a survey of the Creek and identify clear, suggested measures for improvement, including education needed to reduce the human impact on the Creek health. This led to the application to the Colorado Water Conservation Board's (CWCB) Healthy Rivers Fund to implement a stream bank restoration project at Stephens Park and a small grass roots education program.

Originally this restoration project was small, budgeted at only \$12,000 and designed to provide a simple re-vegetation effort. However, because of the attention of the CWCB and the Healthy Rivers Fund, the impacts of the use and the gravity of the situation at the park became apparent, the project eventually grew to a budget of \$65,000. In the end, the Stephens Park project efforts culminated in a \$95,000 major overall that has resulted in improved water quality, increased wildlife and an improved guest experience.

II. PROJECT BACKGROUND

The Town of Vail adopted Environmental Sustainability Strategic Plan Goal 3 states that the Town of Vail shall *“ensure that the natural environment, specifically air and water quality, water quantity, land use and habitat are maintained to current or improved levels of biological health.”* To that end, the purpose of the Stephens Park Stream Bank Restoration Demonstration Project is to implement stream bank stabilization and re-vegetation at the east end of Stephens Park designed to mitigate erosion, sedimentation, and degraded vegetation. Restoring this site will prevent further damage to the riparian area, improve water quality and habitat. Accessibility and recreational opportunities will be greatly enhanced. The current condition of the site has an eroding bank approximately 100 feet long that has been exacerbated by recreational use such as dog fetching and whitewater/fishing access, causing sedimentation, habitat loss and reduced water quality.

Improvements needed are: re-grading the stream bank, riparian improvements, re-vegetation, access improvements including rock work, pathway improvements, and a ramp for accessibility), and turf and irrigation repair.

Total project costs are estimated at \$65,000 (includes all 2010 construction and design work, permitting, and contingency). Initial assessment and design work has already been completed by RiverRestoration in 2009 (\$6,800 already incurred cost). Working with Town residents, staff has written and received a \$6,000 grant from the Colorado Water Conservation Board (CWCB) for construction of this project. In addition, the Eagle River Watershed Council has remaining

funds from 2009 to cover the cost of this project as it fits their mission of improving water quality in the region.

Stephens Park has a high use of multiple recreation; including an off leash dog park, Frisbee golf, whitewater access, fishing, and picnic area. The Park is located on a floodplain terrace at the right of the channel. The right bank of the park has eroded approximately 100 feet in length (Attachment A). This erosion was likely initiated from excessive bank trampling coupled with loss of riparian vegetation at the creek access. There are few large trees and the bank does not have significant root mass on the floodplain bench in this area. Creek processes exacerbate the erosion.

The CWCB recognized the value of the stream bank stabilization opportunities at Stephens Park as well as the visibility and recognition for the Healthy Rivers Fund in Vail, and awarded the Town a \$6,000 matching grant toward riparian improvements at this site.

III. **SCOPE OF WORK**

At the upstream extents of the Stephens Park reach, Gore Creek is encroached by the South Frontage road on the right bank. The channel drops significantly just after the road encroachment. Downstream there are localized areas of the bank that are eroding from the encroachment of the paved pathway, random trampling of the bank, and loss of vegetation. Beavers have likely used healthy mature trees to construct dams; resulting in loss of root mass on the bank and contributing to the erosion. Beaver dams in the reach may need periodic maintenance so that the channel hydraulics and shear forces on the banks are not significantly changed. Beaver screens may need to be installed to protect mature vegetation on the bank.

- **Site Assessment and Survey:** Conducted on November 10, 2009, which included topographic and hydrographic survey of the channel and banks. These data were used to develop the AutoCad base map and the channel profile for the hydraulic model.
- **Hydraulic Modeling:** Developed to analyze potential improvements within the floodway.
- **Final project Design:** The final project design including materials and methods are found in Attachments A and B.
- **Bank re-grading:** Due to erosion, the current steep drop-off will need to be leveled.
- **Bank Stabilization:** Bank stabilization at Stephens Park includes in-channel modifications to hydraulics for concentrated access. A letter is to discuss how the proposed modifications comply with Town of Vail and Federal floodplain development guidelines is found in Attachment C.
- **Boulder work:** Approximately 20 boulders will be excavated and reused for the project
- **Eddy pool:** An eddy pool will be created to slow flows near the input to Gore Creek at the Stephens Park entrance. This will enhance wildlife habitat, reduce erosion and allow for easier output for kayakers.
- **Accessibility:** An accessible access ramp has been included in the bank terracing on both of the design alternatives. Accessible access may be desired to facilitate fishing access for a wider group of citizens and visitors. Potential funding partners may be AXS Vail Valley, and the CDOW “fishing is fun” program.
- **Riparian vegetation Installation – Volunteer Planting Project:** There is an opportunity to incorporate riparian enhancements for increased cover of native

vegetation. Riparian plantings would require protective fencing to keep dogs and wildlife out until successful establishment. Riparian plantings are recommended to increase the root mass and bank stability. Thorny plantings such as prickly gooseberry, raspberry, and rose may be a good option for natural barriers to prevent random trampling of the bank and direct access to less fragile bank areas. Volunteers will be recruited from the annual

V. BUDGET

Project Scope and Budget	Quantity	Unit	Unit Cost	Total Cost	Funding Sources	Start	Finish
Task 1. Site Setup - Final contract with RiverRestoration to finalize design and firm schedule Sept1-Sept 30, 2010							
Mobilization/bonding/insurance	1	LS	\$3,676	\$3,676	Eagle River Watershed Council (ERWSC) Town of Vail Grant funding (\$3,676)	15-May-10	1-Jun-10
Conduct construction survey and stake project area (roughly 200 feet of bank)	1	LS	\$1,200	\$ 1,200	ERWSC Town of Vail Grant funding (1,200)	15-Jun-10	30-Jun-10
Subtotal				\$ 4,876			
Task 2. Best Management Practices							
Traffic Control	1	LS	\$500	\$ 500	ERWSC Town of Vail Grant funding (\$500)	25-Aug-10	30-Sep-10
Establish Construction signage/staging fence/sign for public notice of HRF partnership	1	LS	\$500	\$ 500	ERWSC Town of Vail Grant funding (\$500)	22-Aug-10	30-Sep-10
Purchase and plant native riparian grass mix	0.08	AC	\$200	\$ 2,500	ERWSC Town of Vail Grant funding (\$500)	16-Aug-10	30-Aug-10
Haul route restoration	1	LS	\$1,000	\$ 1,000	ERWSC Town of Vail Grant funding (\$500)	16-Aug-10	30-Aug-10
Protect in place facilities and mature vegetation, stabilize with fencing	1	LS	\$500	\$ 500	ERWSC Town of Vail Grant funding (\$500)	16-Aug-10	30-Aug-10
Establish other BMPs as needed	1	LS	\$500	\$ 500	ERWSC Town of Vail Grant funding (\$500)	Ongoing	Ongoing
Subtotal				\$ 5,500			
Task 3. Bank Stabilization							
Re-grade eroded bank	125	CY	\$10	\$ 1,250	ERWSC Town of Vail Grant funding (\$1,250)	1-Sep-10	7-Sep-10
Order sandstone slabs, have them delivered and placed along bank access points	35	Tons	\$350	\$ 12,250	ERWSC Town of Vail Grant funding (\$12,250)	1-Aug-10	1-Sep-10
Care of water (establish turbidity curtain)	1	LS	\$1,000	\$ 1,000	ERWSC Town of Vail Grant funding (\$1,000)	17-Aug-10	30-Sep-10
Install erosion control blanket	1935	SF	\$3	\$ 4,838	ERWSC Town of Vail Grant funding (\$4,838)	25-Aug-10	25-Aug-10
Install 3' minus gravel bedding	4	CY	\$10	\$ 40	ERWSC Town of Vail Grant funding (\$40)	1-Sep-10	15-Sep-10
Install filter fabric	55	SY	\$2	\$ 110	ERWSC Town of Vail Grant funding (\$110)	1-Sep-10	15-Sep-10
Subtotal				\$ 19,488			

Task 4. Riparian Planting							
Install irrigation included controller and valves	1	LS	\$1,400	\$ 1,400	CWCB Healthy Rivers Fund Grant funding (\$1,400)	15-Sep-10	17-Sep-10
Install 6 native conifers (8' height each, includes planting and material)	6	EA	\$300	\$ 1,800	CWCB Healthy Rivers Fund Grant funding (\$1,800)	17-Sep-10	17-Sep-10
Install native riparian shrubs	7	EA	\$65	\$ 455	CWCB Healthy Rivers Fund Grant funding (\$455)	17-Sep-10	20-Sep-10
Install native riparian shrubs	11	EA	\$65	\$ 715	CWCB Healthy Rivers Fund Grant funding (\$715)	17-Sep-10	20-Sep-10
Willowstaking	137	SY	\$7	\$ 957	CWCB Healthy Rivers Fund Grant funding (\$957)	20-Sep-10	30-Sep-10
Invasive weed control treatment	1	AC	\$90	\$ 90	CWCB Healthy Rivers Fund Grant funding (\$90)	30-Sep-10	5-Oct-10
Top soil imported	18	CY	\$40	\$ 717	CWCB Healthy Rivers Fund Grant funding (\$583). ERWSC Town of Vail Grant funding (\$134)	15-Sep-10	15-Sep-10
Deliver 6' landing and place	1	EA	\$500	\$ 500	ERWSC Town of Vail Grant funding (\$500)	25-Sep-10	25-Sep-10
Install gravel path/concrete work	240	SF	\$21	\$ 5,040		1-Sep-10	30-Sep-10

Task 5. Interpretive Sign							
Artist rendering	1	EA	\$800	\$ 800			
Digital Design	1	EA	\$700	\$ 700			
Concrete, materials and installation	1	EA	\$900	\$ 900			
Subtotal				\$ 14,074			
Construction Total				\$ 43,938			
Final Design/Permits				\$ 8,500	ERWSC Town of Vail Grant funding (\$8,500)	1-Jun-10	1-Jul-10
Engineer Construction Management				\$ 2,500	ERWSC Town of Vail Grant funding (\$2,500)		
Prior year design expenses				\$ 7,000	ERWSC Town of Vail Grant funding (\$7,000)		
Subtotal				\$ 18,000			
15% Contingency				\$ 7,085	ERWSC Town of Vail grant funding (\$7,085)		
Project Estimate Total				\$ 69,023			
Reduced by expenses paid				\$ (7,000)	Paid - TOV Public Works Park Maintenance funding		
Required 2010 Project Budget				\$ 62,023			
Proposed Budget Sources							
Town of Vail Funding				\$ 62,023			
Colorado Water Conservation Board Grant				\$ 6,000			
Proposed Total Project Budget				\$ 68,023			

V. ADDITIONAL ENVIRONMENTAL EDUCATION BENEFITS

In addition to habitat and stream bank restoration, recreational opportunities and an enhancement of a well utilized park, this project provides an excellent opportunity for demonstration of environmental stewardship in Vail. As host of the Colorado Watershed Assembly's (CWA) Annual Watershed Conference at the Vail Cascade October in 2009, the Town hosted an environmental education tour to the Black Gore Creek Basin of Last Resort on Hwy I-70, and a tree planting event on the Vail Golf Course. As part of the Stephens Park project, event organizers requested an expert from the Resources Conservation Service (NRCS) provide a willow planting workshop at Stephens Park and allow volunteers to help with

the re-vegetation effort as a part of the demonstration project. This event serves as a great opportunity for Vail to provide visitors an environmental education opportunity, and showcase the Town's dedication to the environment and outstanding park environment, while reducing the costs of landscaping at the site.

VII. TIMELINE

2010-2011 Season	Activity
March 1 – April 1	Final Project Design
April 1 – April 15	Flood Plain Analysis – Army Corps of Engineers/Town Engineer
April 15 – May 30	Department of Wildlife Review
May 30 – June 30	Construction documents – Release RFP
June 30 – July 30	Finalize construction contract
Aug. 1 – Aug. 30	Finalize planting selection, order plants, coordinate with CWA planting event
Sept. 1-Sept. 30	Construction (excavation, boulder work)
Oct. 5-7	Willow planting workshop
2011-2012 Season	Interpretive Sign Development and Education Program
November – February	Artist painting – Stephens Park, flora/fauna study, insect assessment, rules and regulations development for public use.
March	Digitize artist painting, develop text, set in resin
May	As weather and ground thaw allows, pour concrete, install interpretive sign at Stephens Park

VIII. Results

Final bank restoration completed in accordance with the details in the planning document, found in the binder in attachment B.

- Construction complete as of November, 2011
 - Flagstone bank stabilization
 - Pervious surface path and ramp - ADA Accessibility
 - Additional stone seating area
 - Bank around 40 ft- tall spruce trees stabilized
 - Eddy pool installed, fish habitat enhanced
- Volunteer Planting Event, October 2011

- Roughly 30 volunteers from the annual Colorado Watershed Conference took part in the planting event, installing native willows, alders, rose bushes and other vegetation lining the bank at Stephens Park.
- Interpretive Sign Developed (Attachment D) (installation May 2012)
 - A local artist, Charmayne Bernhardt, was commissioned to paint the Stephens Park site, bank view, complete with identification of local flora and fauna.
 - Text was developed to explain to visitors the importance of the riparian area, aquatic life identification, the restoration project, and rules of the park.

VIII. ATTACHMENTS

- A. Stephens Park Re-vegetation Project Site Design
- B. Stephens Park Project Planning Binder
- C. Flood Plain Compliance Letter
- D. Stephens Park Interpretive Sign
- E. Photo Album

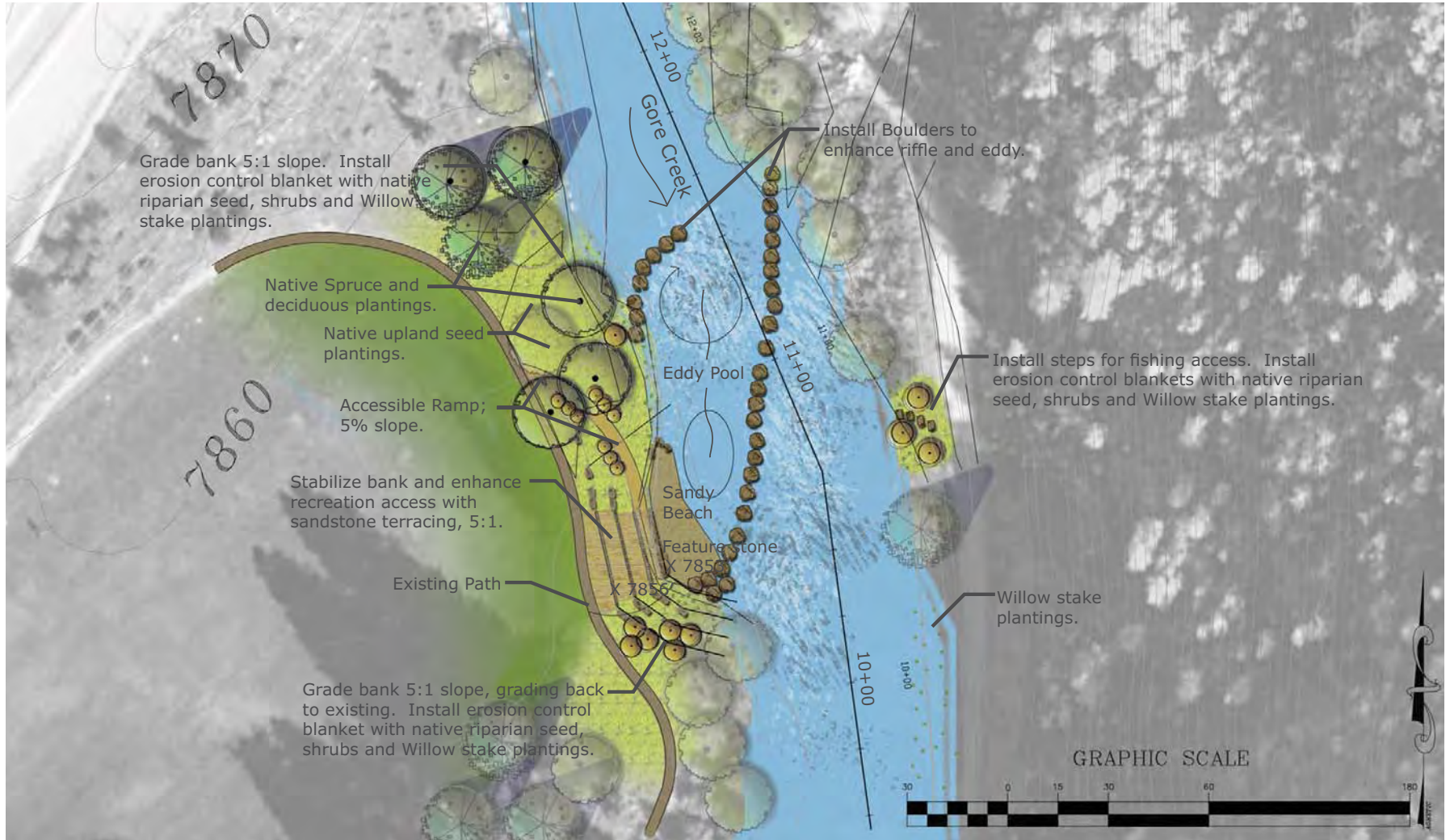

Option 2: Stephens Park Recreation Enhancement

Vail, Colorado
December 18, 2009

STEPHEN'S PARK BANK STABILIZATION TOWN OF VAIL, CO JULY, 2010

DRAWING INDEX

PLATE NO	TITLE
G1	VICINITY MAP, DRAWING INDEX, LEGEND
C1	OVER VIEW
C2	PLAN VIEW
C3	PLAN VIEW
C4	CONSTRUCTION BMP TYPICAL PLAN
D1	NON-POINT SOURCE POLLUTION CONTROL DETAILS
D2	TYPICAL CONSTRUCTION DETAILS
D3	EROSION CONTROL BLANKET DETAILS
D4	PLANT INSTALLATION DETAILS

CONTACTS

1. Mr. Gregg Barrie
Town Landscape Architect
Town of Vail
(970)-479-2337

2. Mr. Jason Carey, P.E.
River Engineer
RiverRestoration.org, LLC.
(970)-947-9568

3. Ms. Kendall Bakich
Aquatic Biologist
Colorado Division of Wildlife
(970)-947-2924

LOCATION MAP

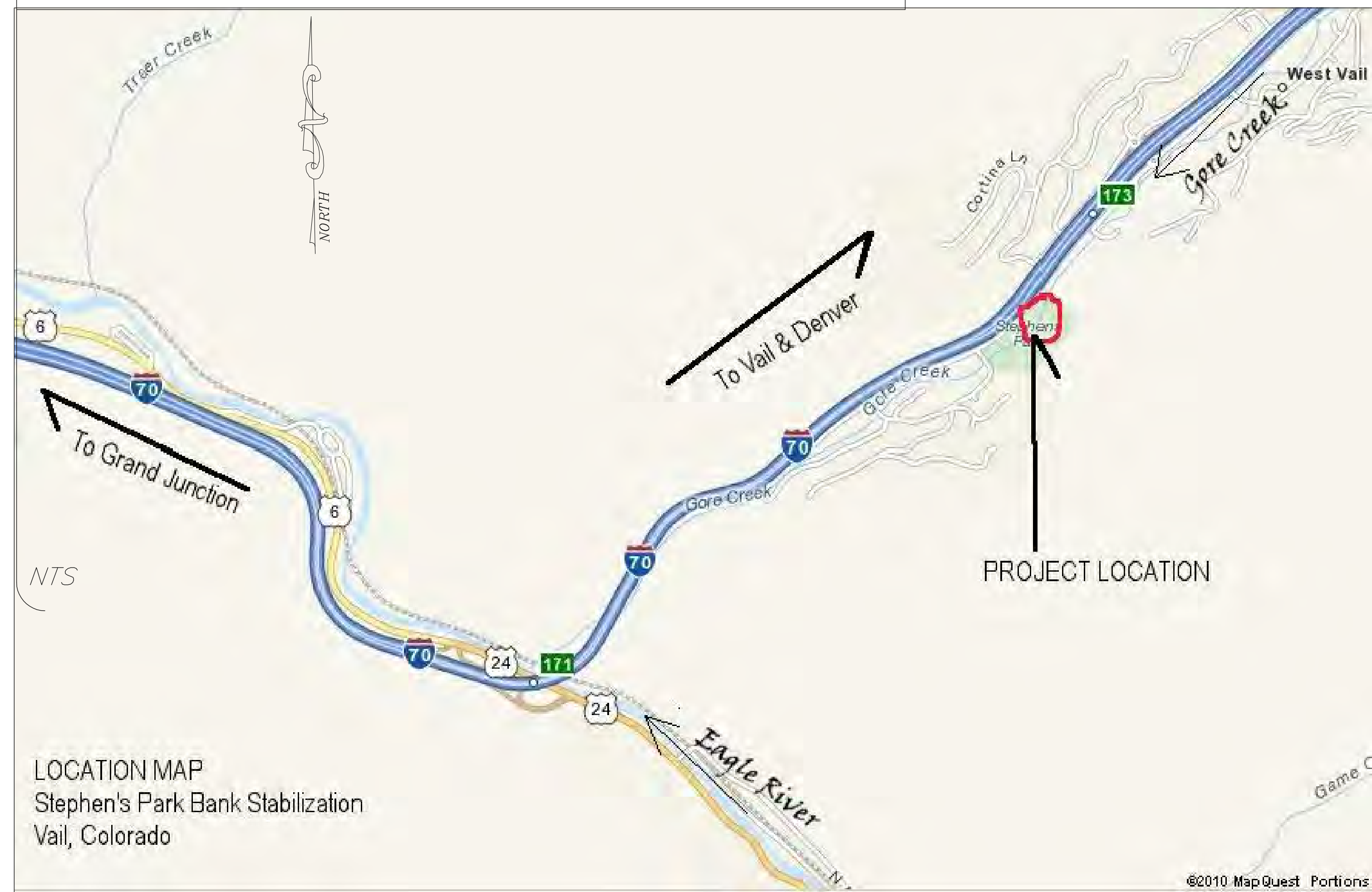

VICINITY MAP

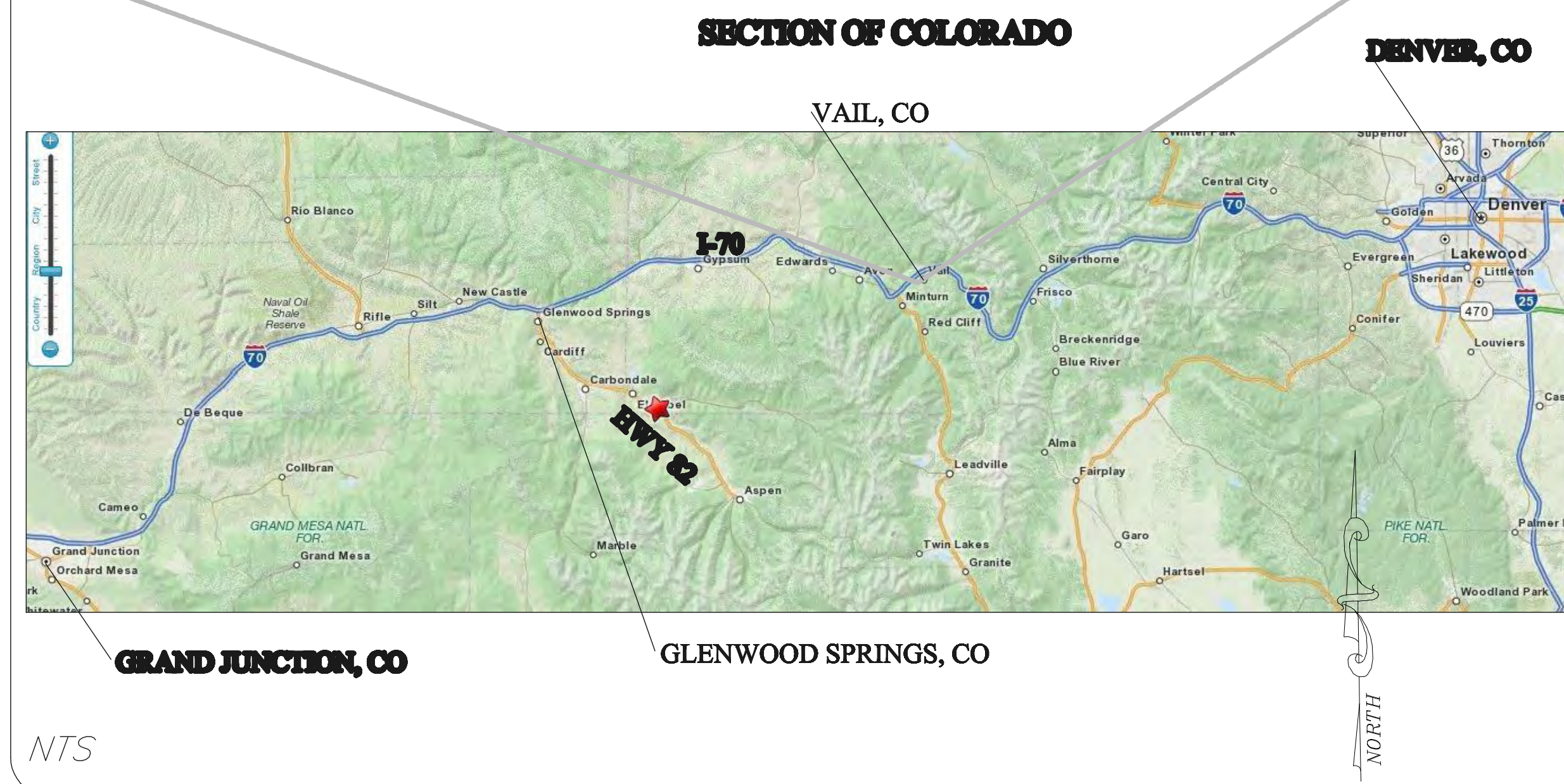

General Notes

TOWN OF VAIL STEPHEN'S PARK BANK STABILIZATION PRELIMINARY DESIGN COVER

NOT FOR CONSTRUCTION

No.	Revision/Issue	Date

Firm Name and Address



P.O. Box 2123
Glenwood Springs, CO 81602
www.RiverRestoration.org

Project Name and Address

TOWN OF VAIL
GORE CREEK

Project	STEPHENS	Sheet	G-1
Date	06-29-2010	Scale	
Scale	NTS		

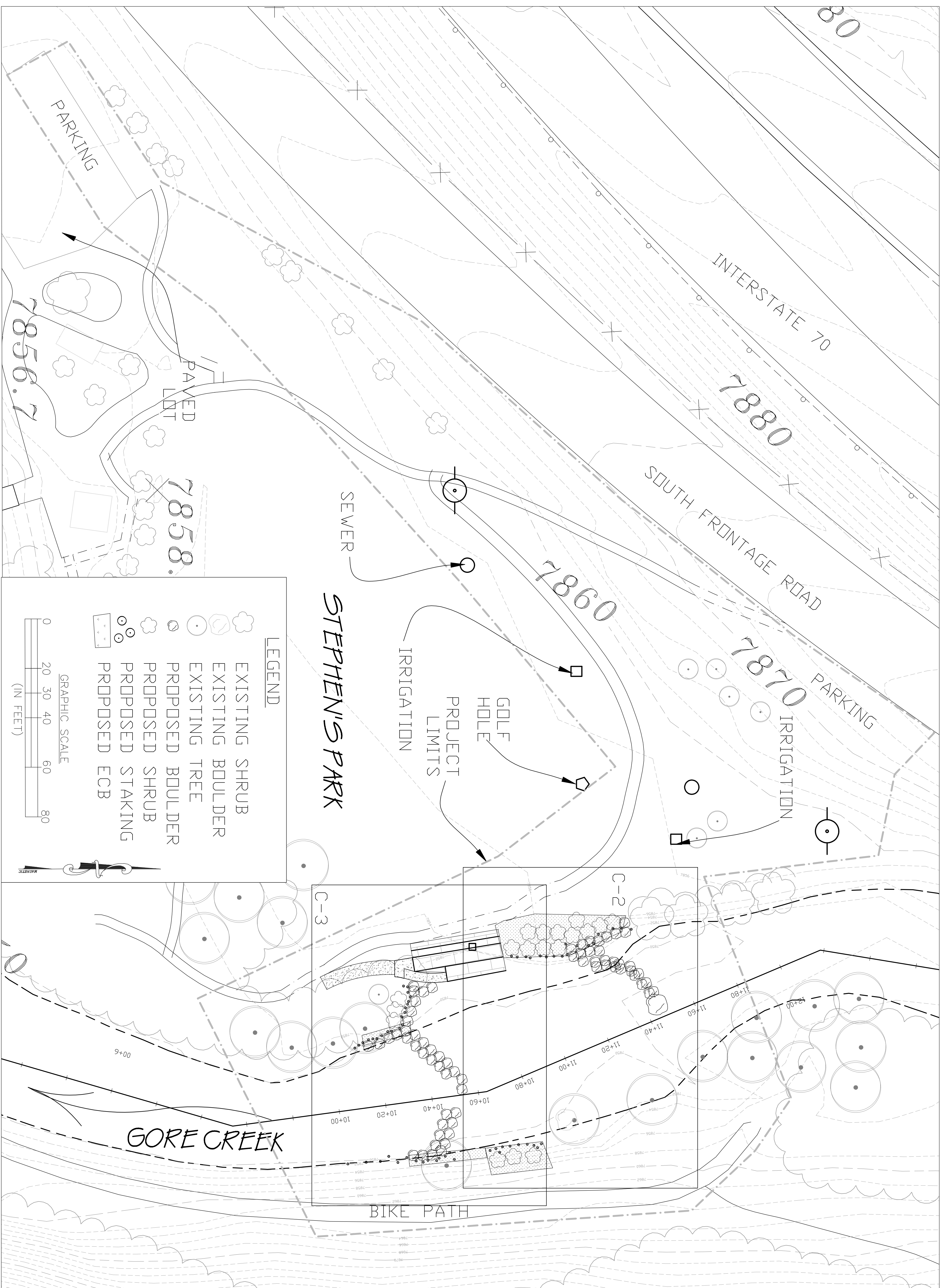

LEGEND

- EXISTING SHRUB
- EXISTING BOULDER
- EXISTING TREE
- PROPOSED BOULDER
- PROPOSED SHRUB
- PROPOSED STAKING
- PROPOSED ECB

GRAPHIC SCALE
 0 20 30 40 60 80
 (IN FEET)

STEPHEN'S PARK

IRRIGATION

GOLF HOLE

PROJECT LIMITS

SEWER

PAVED LOT

PARKING

INTERSTATE 70

SOUTH FRONTAGE ROAD

PARKING

IRRIGATION

GORE CREEK

BIKE PATH

General Notes

TOWN OF VAIL STEPHEN'S PARK BANK STABILIZATION PRELIMINARY DESIGN PROJECT LIMITS

NOT FOR CONSTRUCTION

No.	Revision/Issue	Date

Project Name and Address

TOWN OF VAIL
GORE CREEK



From Name and Address
 P.O. Box 2123
 Glenwood Springs, CO 81602
 www.RiverRestoration.org

Project: **STEPHENS**

Date: **06-29-2010**

Scale: **1" = 20'**

Sheet: **C-1**

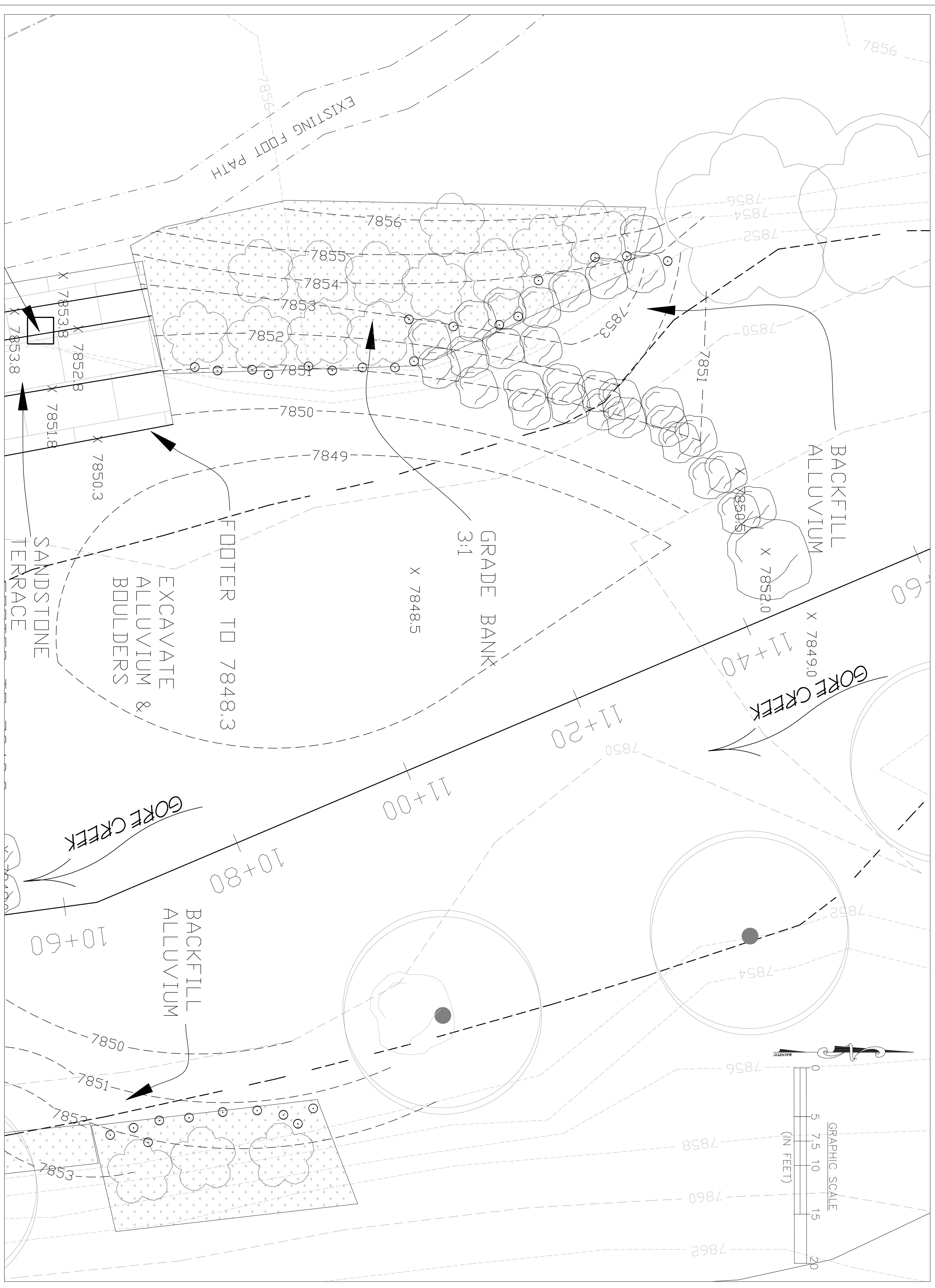

General Notes

TOWN OF VAIL STEPHEN'S PARK BANK STABILIZATION PRELIMINARY DESIGN PLAN VIEW

NOT FOR CONSTRUCTION

No.	Revision/Issue	Date

From Name and Address

 P.O. Box 2123
 Glenwood Springs, CO 81602
 www.RiverRestoration.org

Project Name and Address
 TOWN OF VAIL
 GORF CREEK

Project: STEPHENS
 Date: 06-29-2010
 Scale: 1" = 5'
 Sheet: C-2

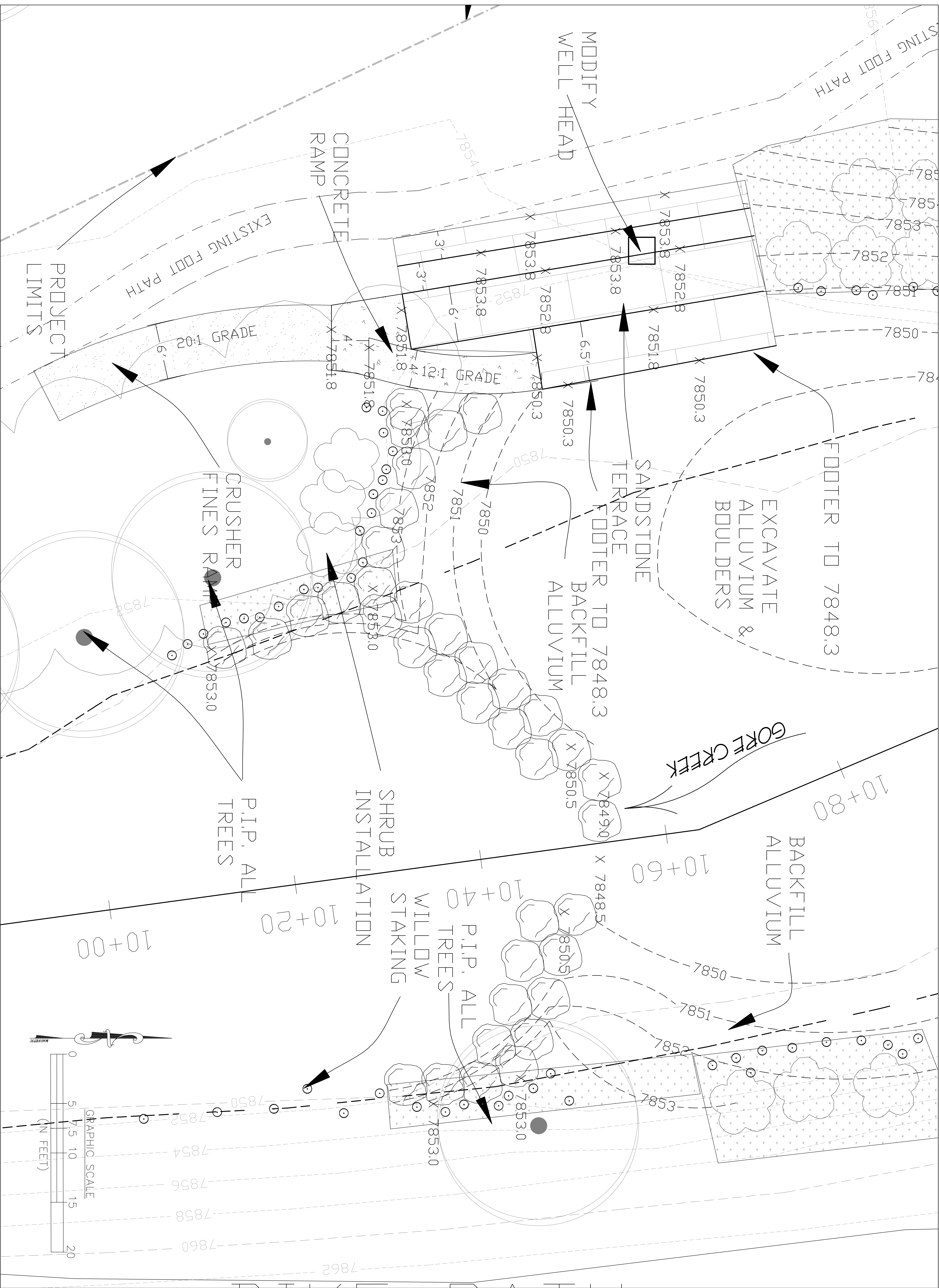

General Notes

TOWN OF VAIL STEPHEN'S PARK BANK STABILIZATION PRELIMINARY DESIGN PLAN VIEW

NOT FOR CONSTRUCTION

No.	Revision/Issue	Date

From Name and Address
RIVER RESTORATION ORG
 P.O. Box 2123
 Glenwood Springs, CO 81602
 www.RiverRestoration.org

Project Name and Address
**TOWN OF VAIL
GORE CREEK**

Project **STEPHENS** Sheet
 Date **06-29-2010** **C-3**
 Scale **1" = 5'**

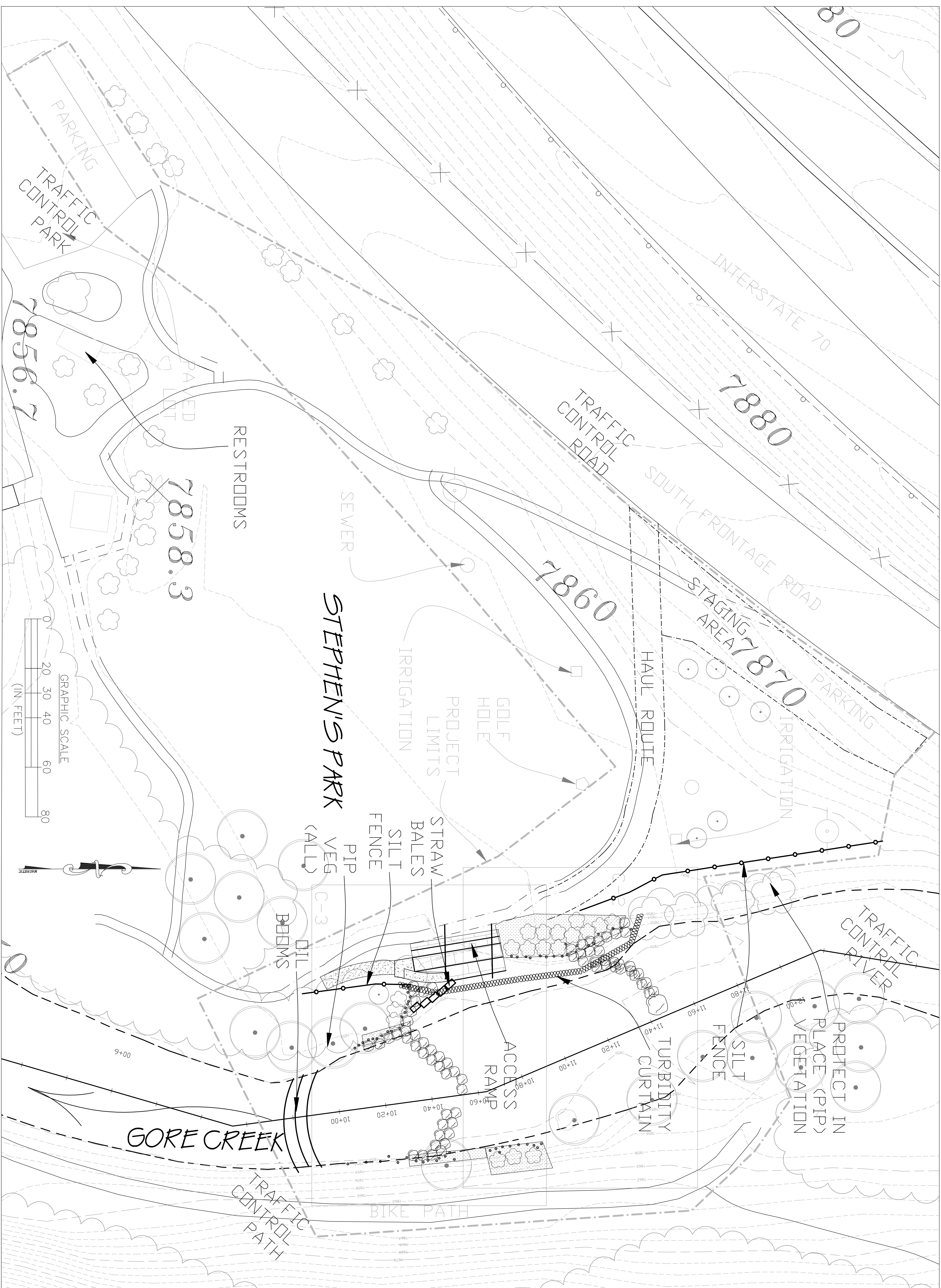

General Notes

TOWN OF VAIL STEPHEN'S PARK BANK STABILIZATION PRELIMINARY DESIGN BEST MANAGEMENT PRACTICES (TYP.)

NOT FOR CONSTRUCTION

No.	Revision/Issue	Date

From Name and Address

RIVER
 RESTORATION ORG
 P.O. Box 2123
 Glenwood Springs, CO 81602
 www.RiverRestoration.org

Project Name and Address
TOWN OF VAIL
GORE CREEK

Project **STEPHENS** Sheet
 Date **06-29-2010** **C-4**
 Scale **1" = 20'**

**TOWN OF VAIL
STEPHEN'S PARK BANK STABILIZATION
PRELIMINARY DESIGN
NON-POINT SOURCE POLLUTION CNTRL**

NOT FOR CONSTRUCTION

No.	Revision/Issue	Date

Firm Name and Address



RIVER RESTORATION.ORG
P.O. Box 2123
Glenwood Springs, CO 81602
www.RiverRestoration.org

Project Name and Address

**TOWN OF VAIL
GORE CREEK**

Project	STEPHENS	Sheet	D-1
Date	06-29-2010	Scale	
Scale	NTS		

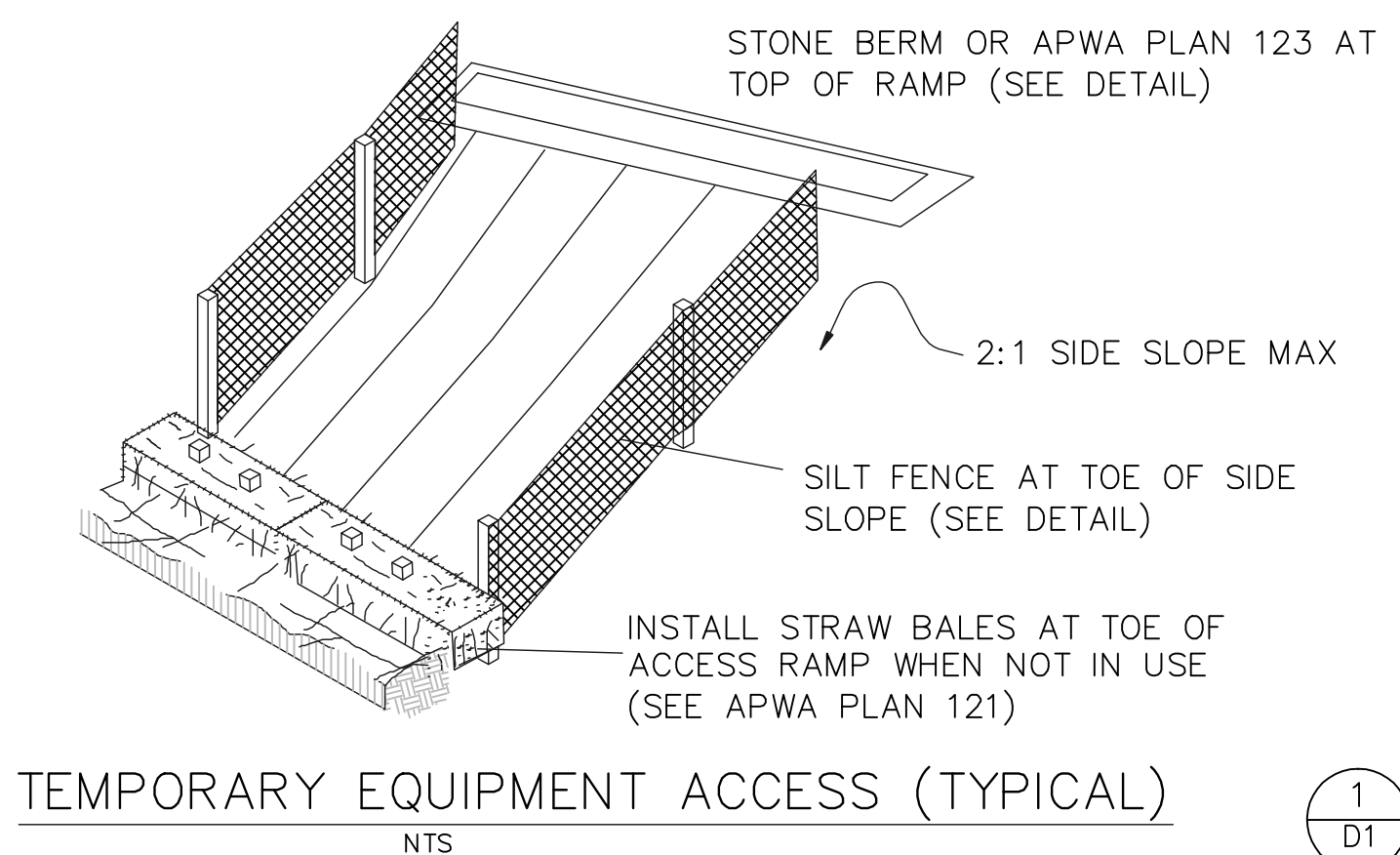

1
D1

NOTE: ANCHORING WITH BUOYS, AS SHOWN, REMOVES ALL VERTICAL FORCES FROM THE CURTAIN. HENCE, THE CURTAIN WILL NOT SINK FROM WIND OR CURRENT LOADS.

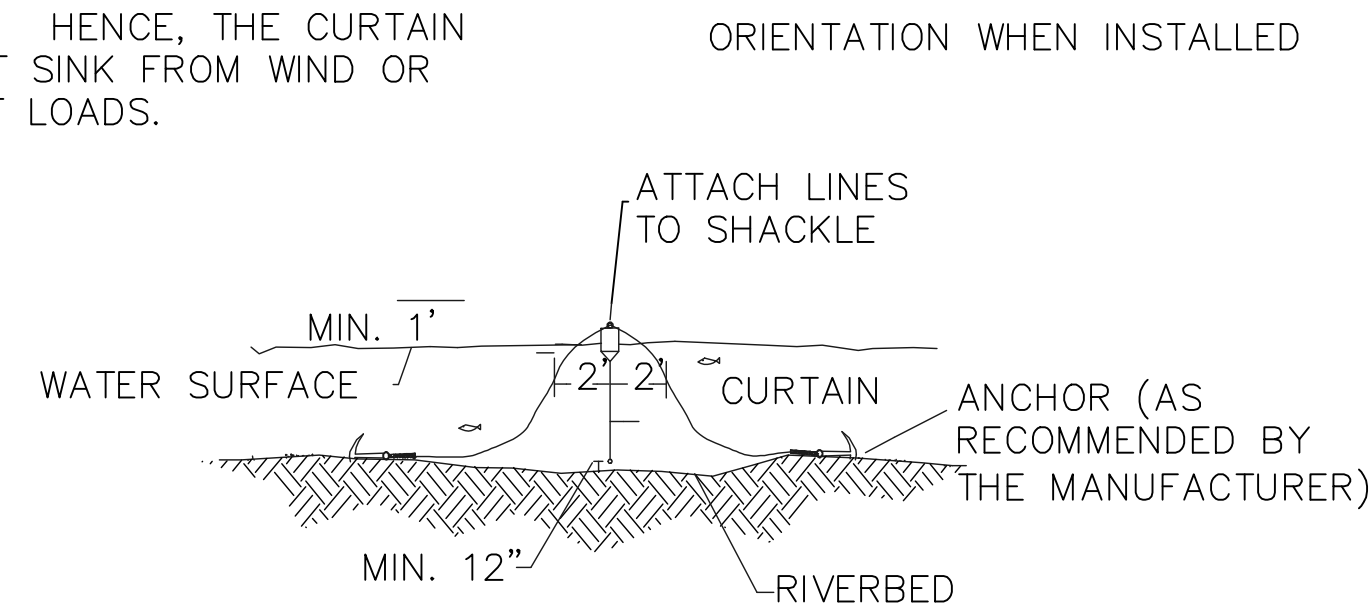

TURBIDITY CURTAIN SECTION (TYPICAL)

NTS

TYPICAL LAYOUT FOR STREAMS AND RIVERS TO BE PLACED DOWNSTREAM OF ANY EQUIPMENT WORKING IN THE WET

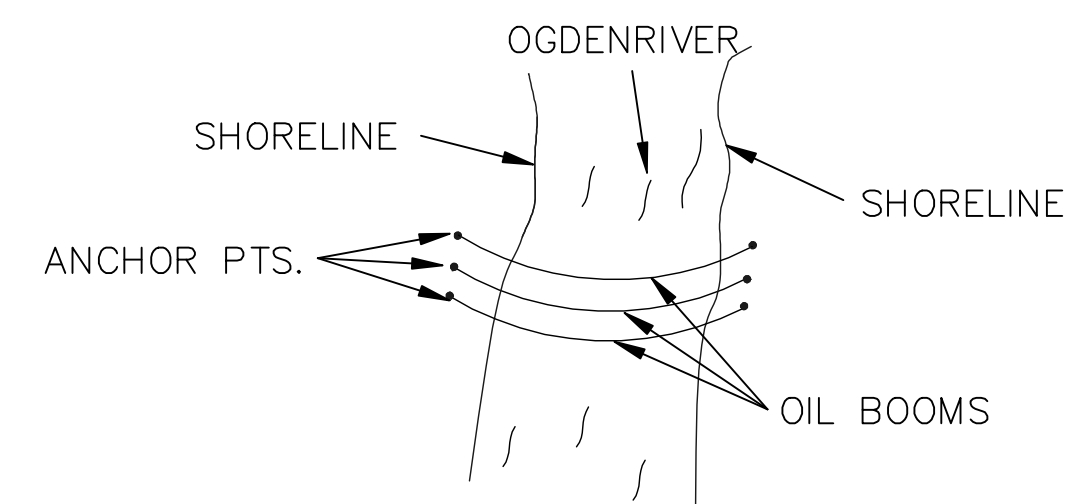

OIL BOOM (TYPICAL)

PLAN VIEW - NTS

4
D1

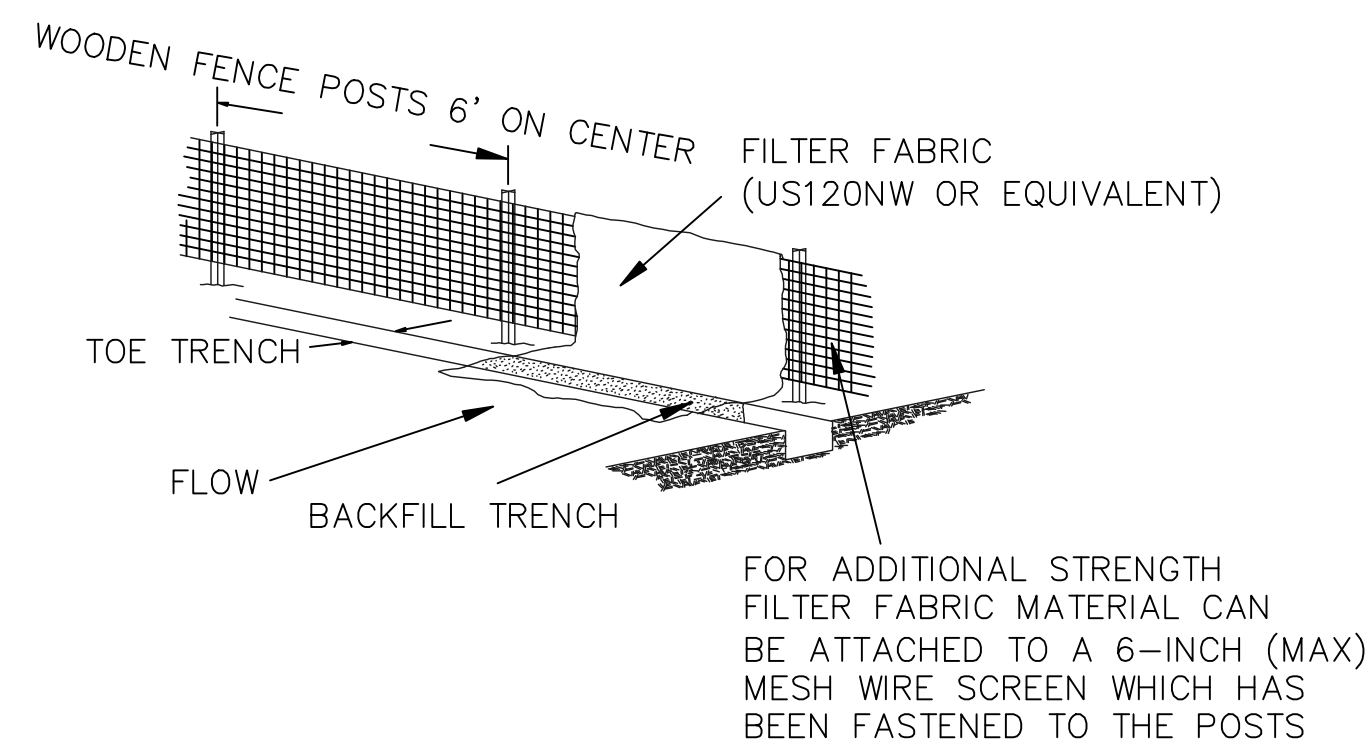
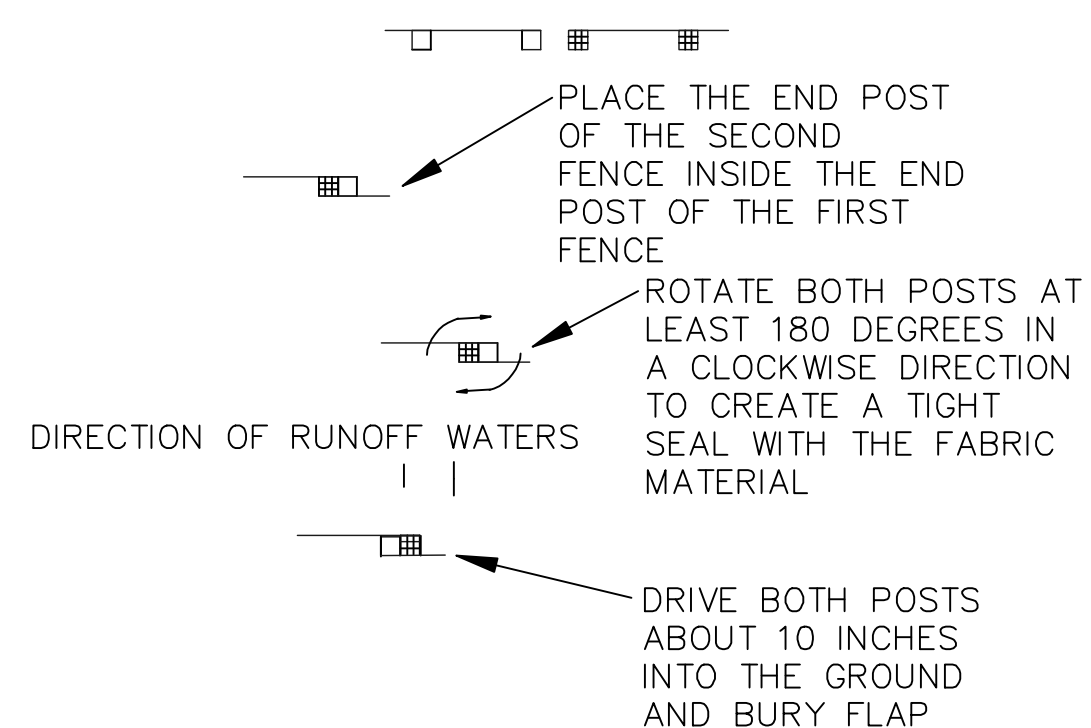
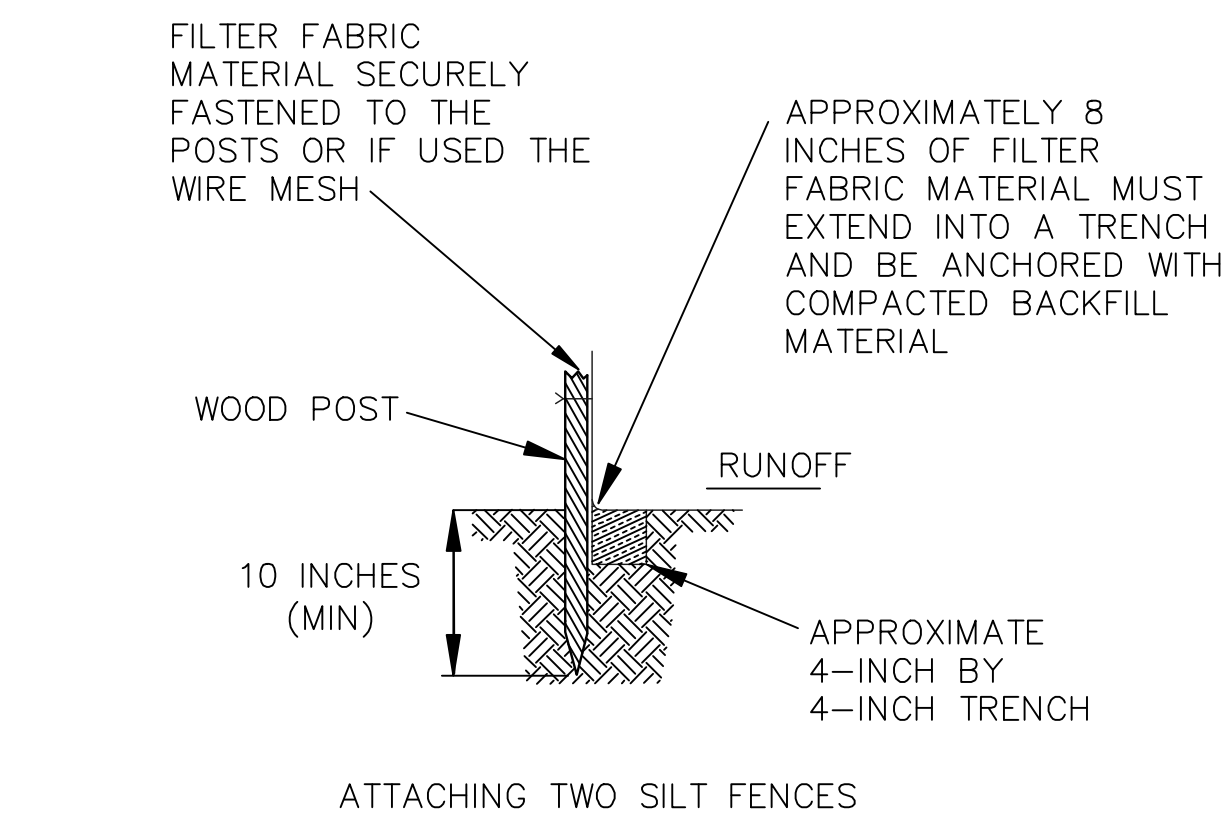

SILT FENCE (TYPICAL)

NTS

2
D1

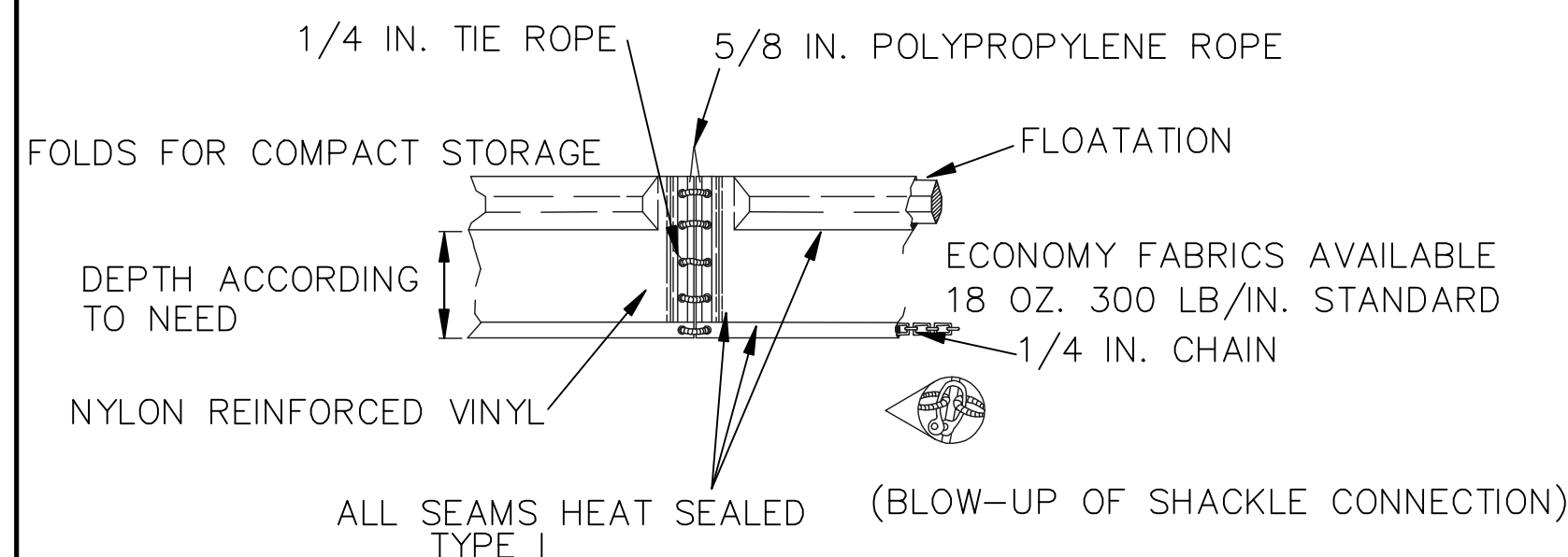

TURBIDITY CURTAIN (TYPICAL)

NTS

TYPICAL LAYOUTS STREAMS, PONDS, AND LAKES (PROTECTED AND NON-TIDAL)

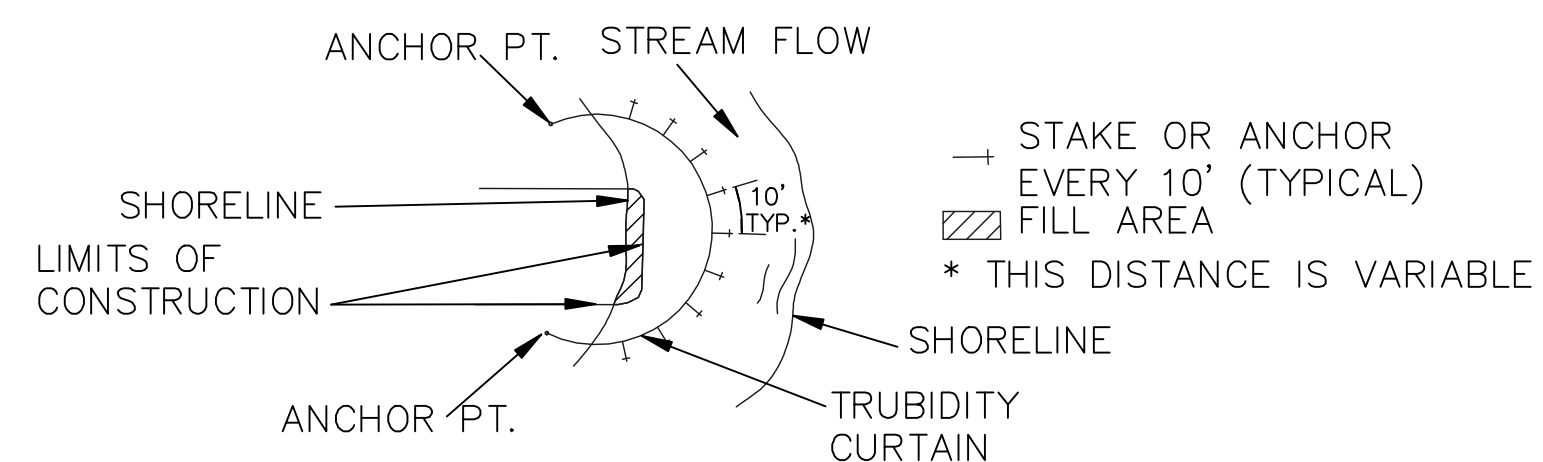

TURBIDITY CURTAIN (TYPICAL)

NTS

3
D1

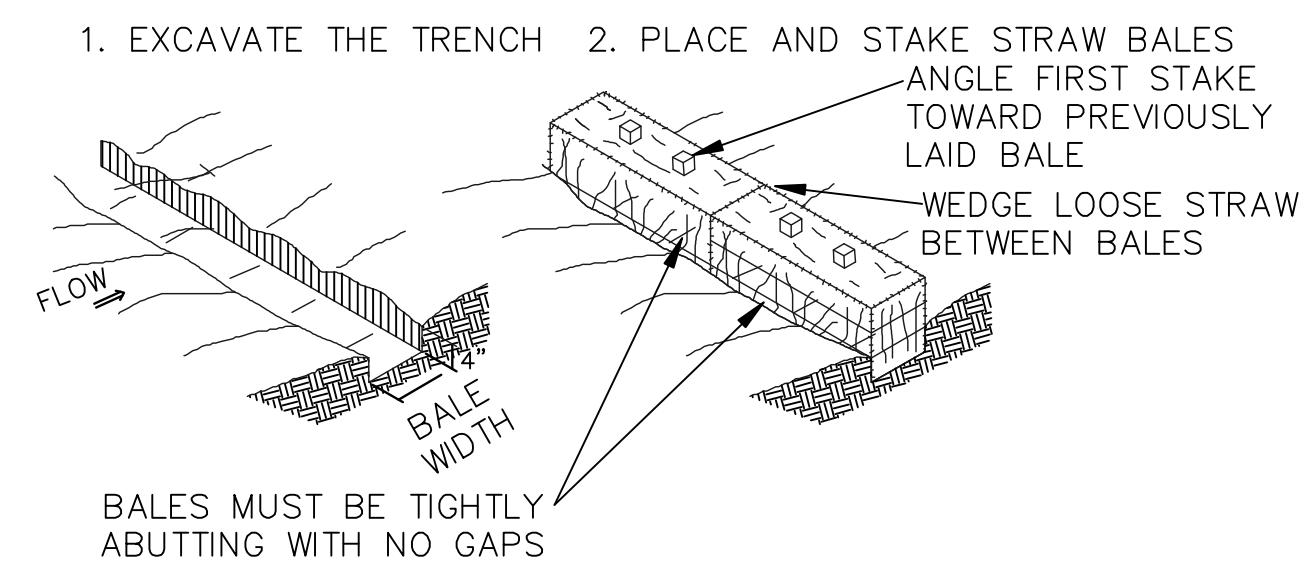
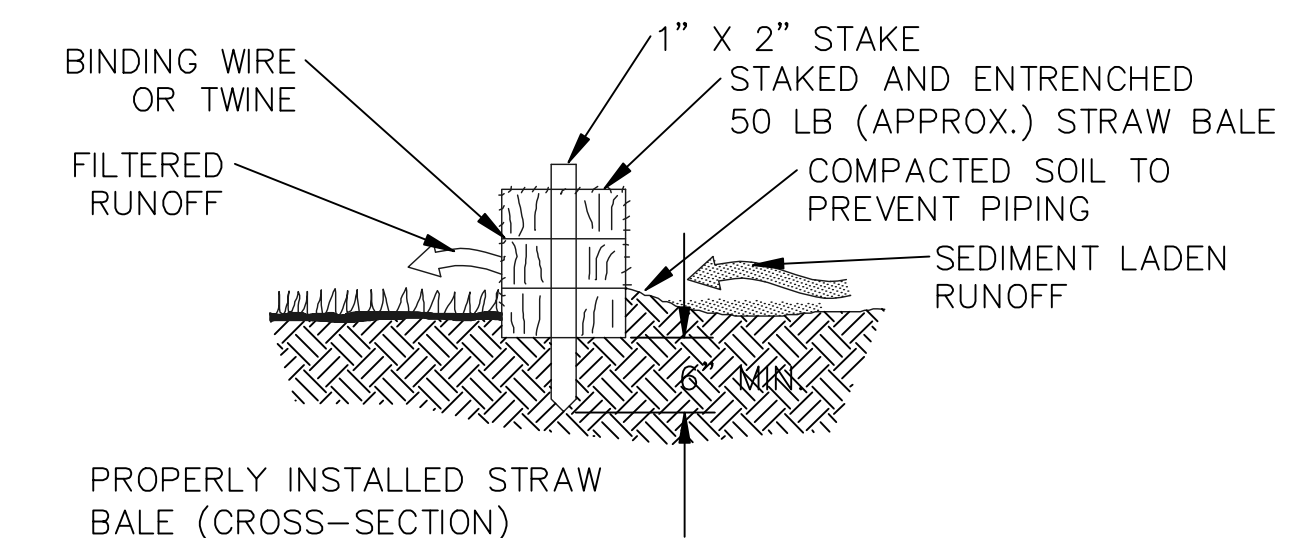

STRAW BALE (TYPICAL)

NTS

5
D1

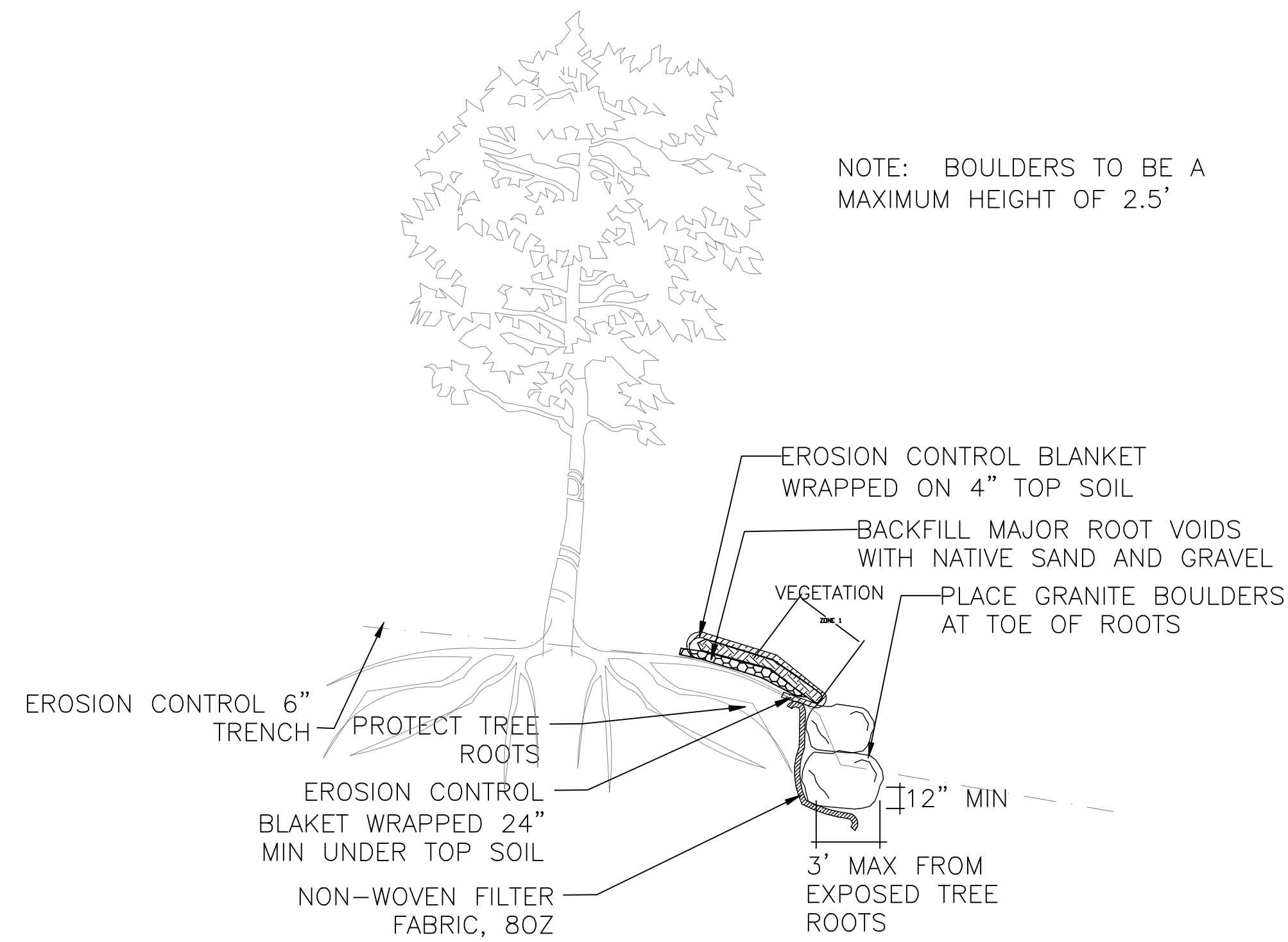
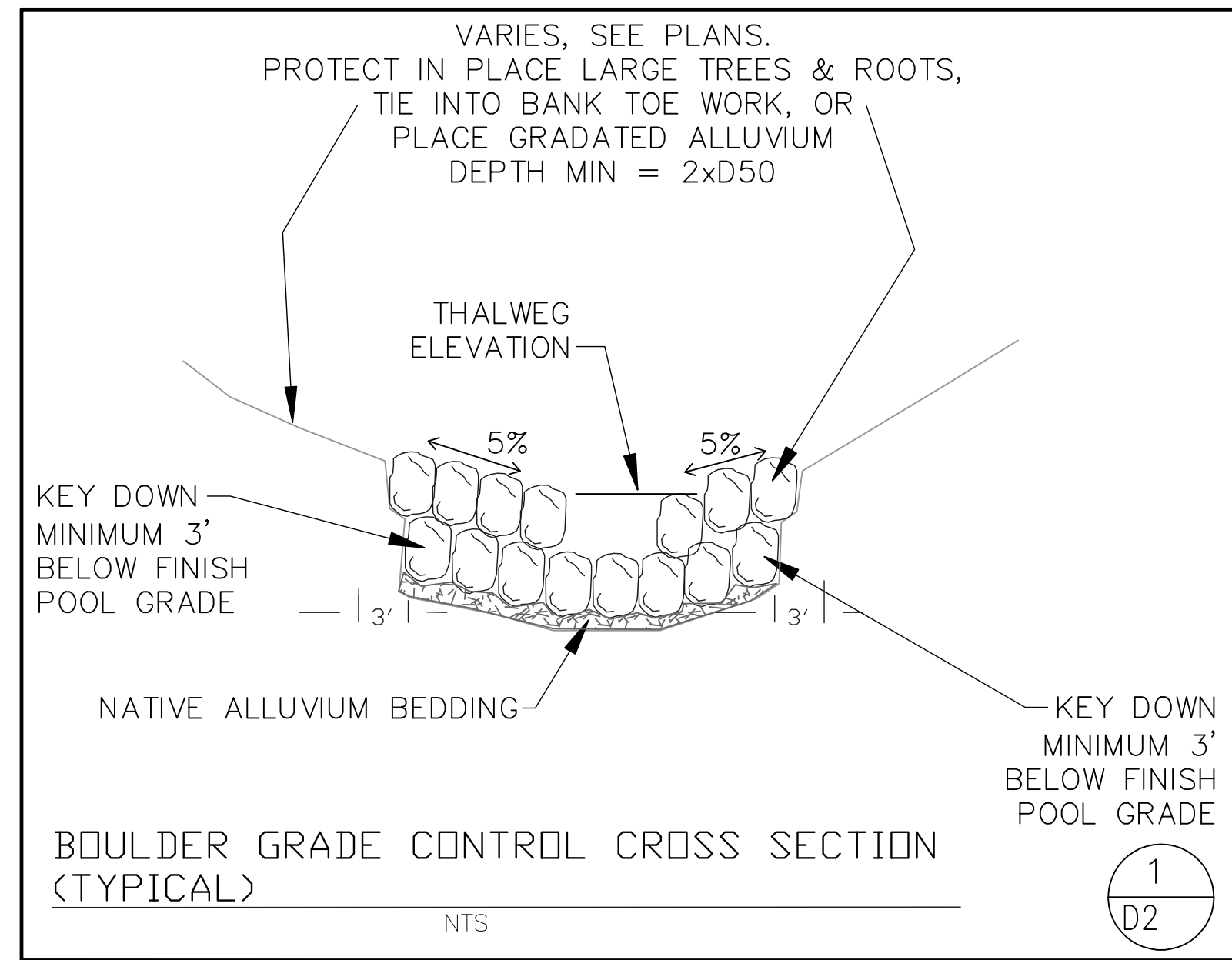

3 D2 EXPOSED TREE ROOT BANK STABILIZATION
SCALE: NTS

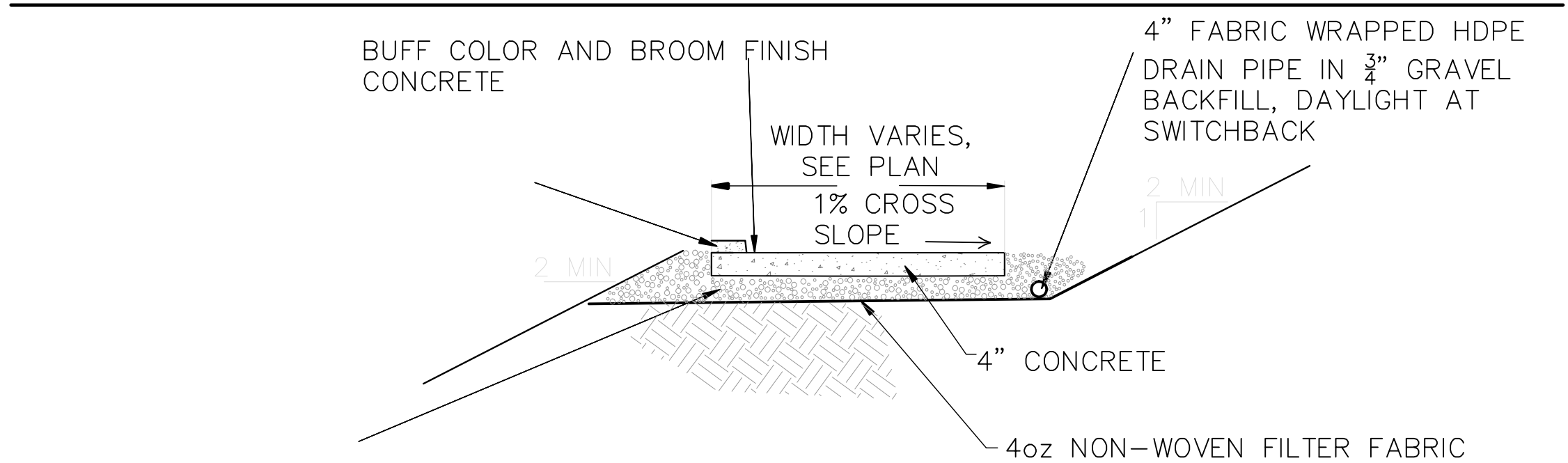
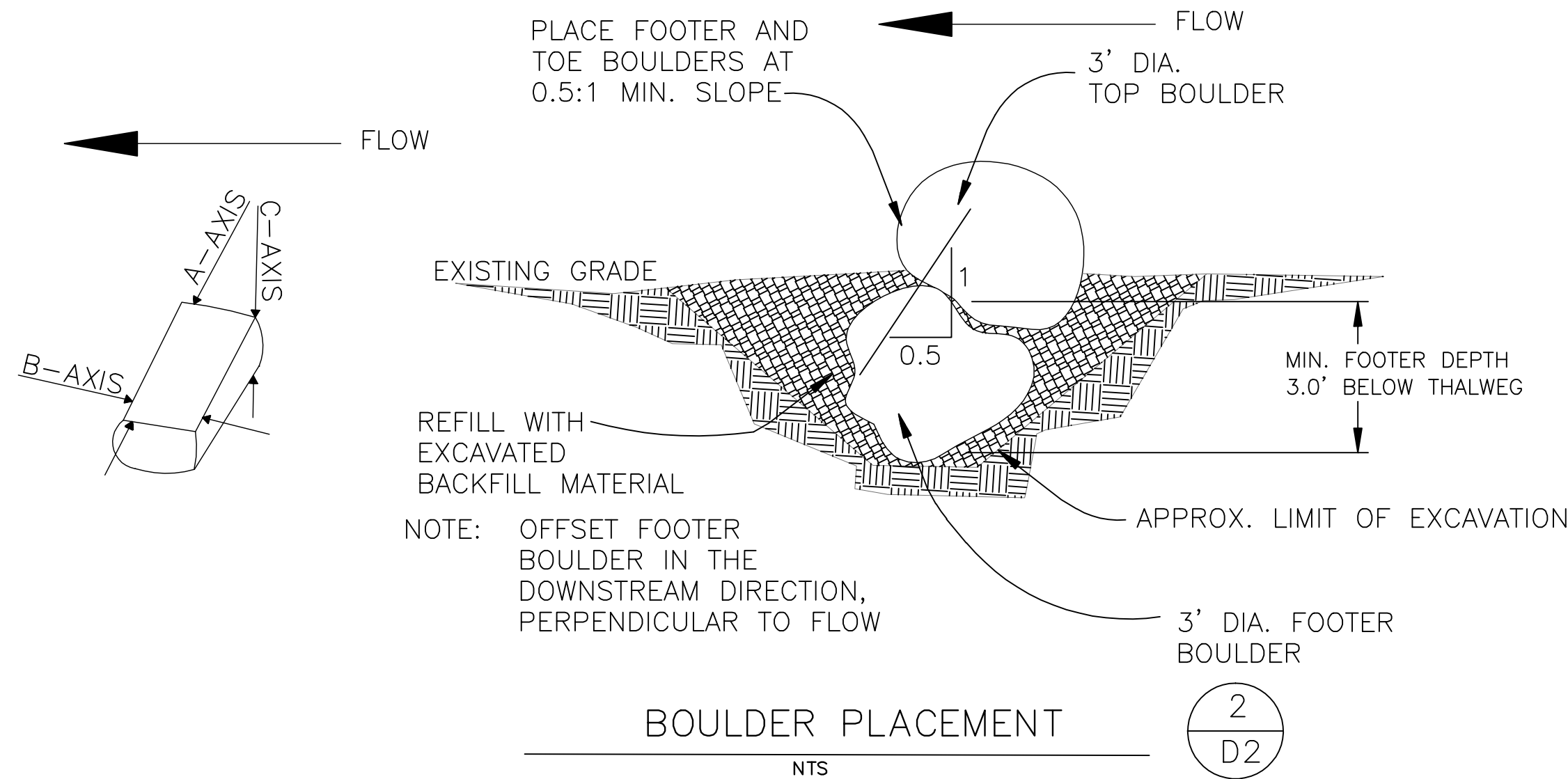

CONCRETE RAMP DETAIL
NTS

5 D2

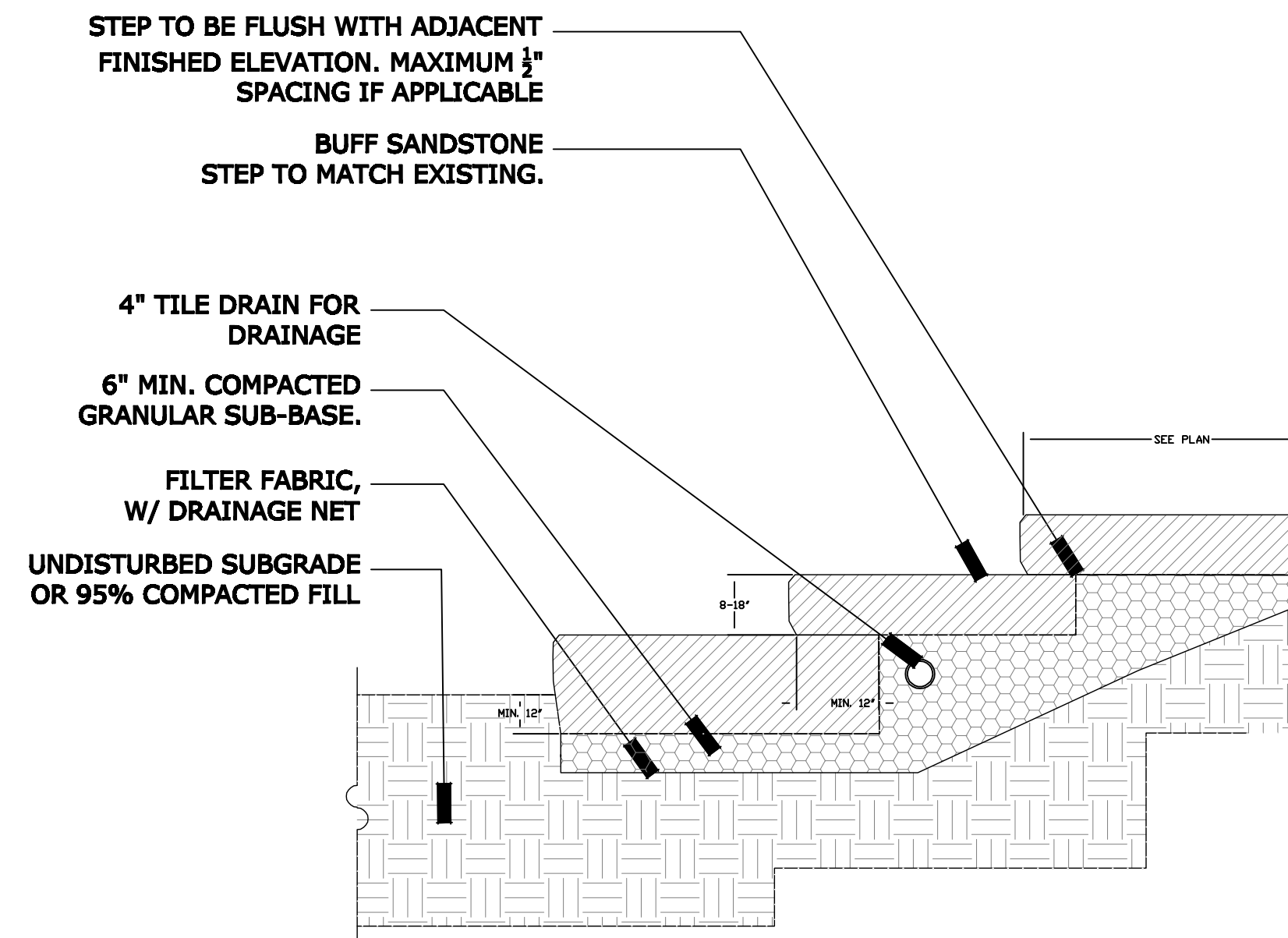

4 D2 SANDSTONE TERRACE TYP.
SCALE: NTS

General Notes

TOWN OF VAIL STEPHEN'S PARK BANK STABILIZATION PRELIMINARY DESIGN BOULDER STRUCTURE DETAILS

NOT FOR CONSTRUCTION

No.	Revision/Issue	Date

Firm Name and Address



RIVER
RESTORATION.ORG

P.O. Box 2123
Glenwood Springs, CO 81602
www.RiverRestoration.org

Project Name and Address

**TOWN OF VAIL
GORE CREEK**

Project	STEPHENS	Sheet	D-2
Date	06-29-2010		
Scale	NTS		

Notes:

1. Contractor Shall Use All Natural 100% Biodegradable Erosion Control Blankets, Type 1, Type 2, Type 3.
2. Stake Blanket In Place, Cut Holes Through The Layers, Then Dig The Planting Holes In The Soil. Staple Around Plant Every 1'.
3. Erosion Control Material Must Be Placed Loosely Over Ground Surface. Do Not Stretch.
4. Excavate A 6" Wide By 6" Deep Trench Along The Top Of The Slope. The Trench Shall Run Along The Length Of The Installation. Staple Blanket Along Bottom Of Trench, Fill With Compacted Soil, Overlap Blanket Towards Toe Of Slope, And Secure With Staples Every 2'.

*Approximately 200 Staples Per 8.0' Roll.

Drawings Not To Scale

8.0' Wide Blanket Shown

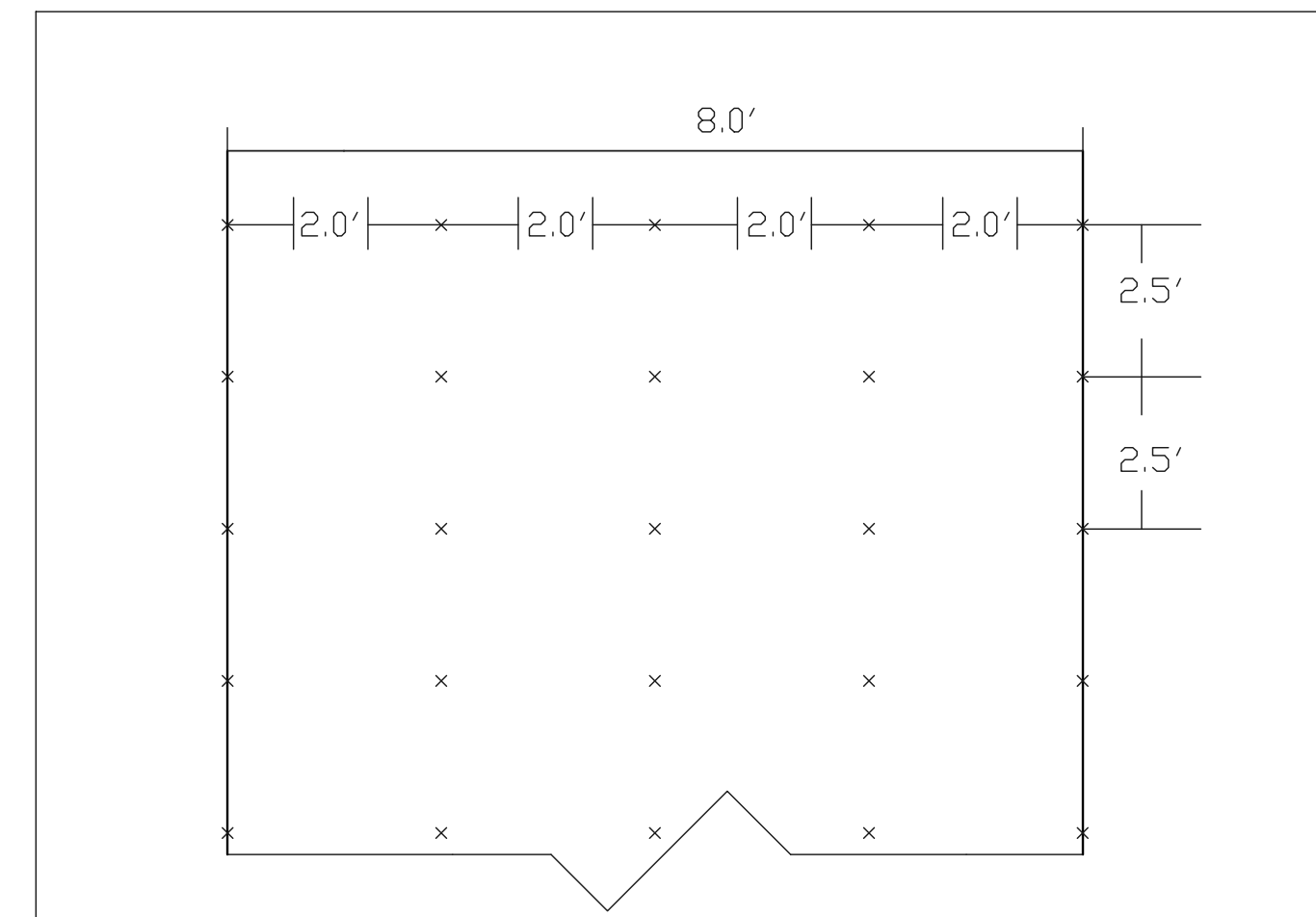
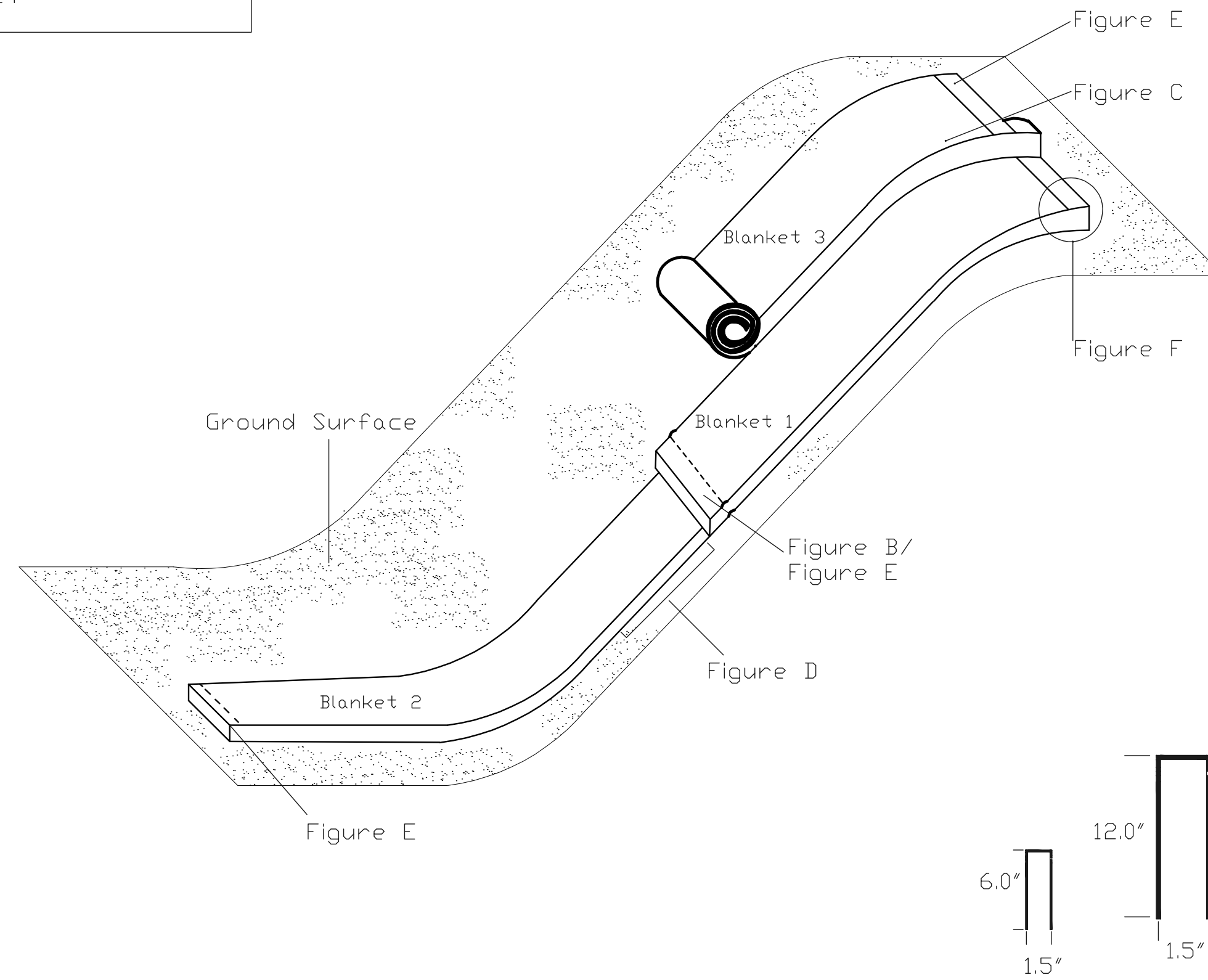

* Denotes Staple Location
Figure D- Plan View

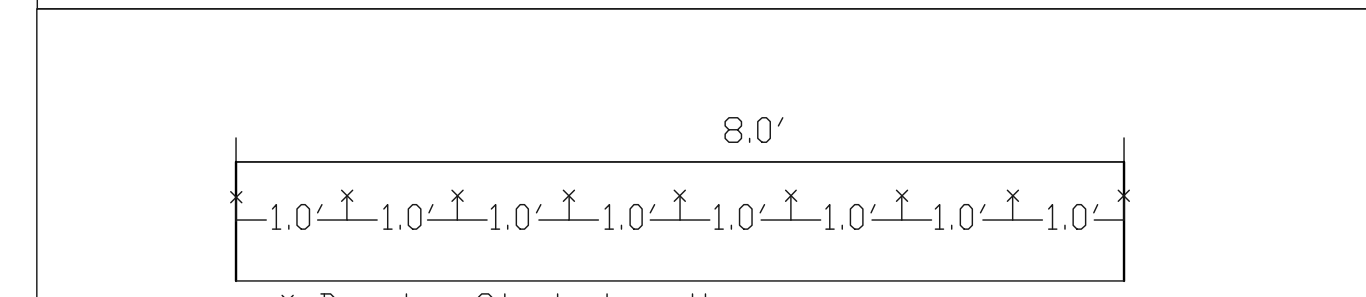

* Denotes Staple Location
Figure E- Plan View

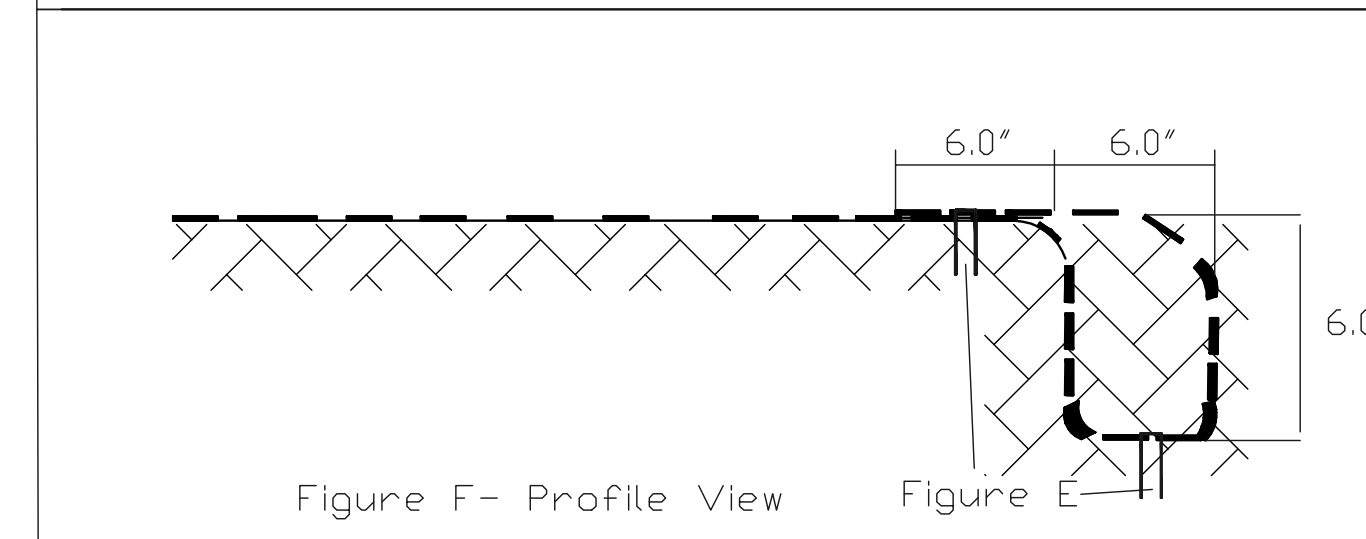

Figure F- Profile View

Figure E

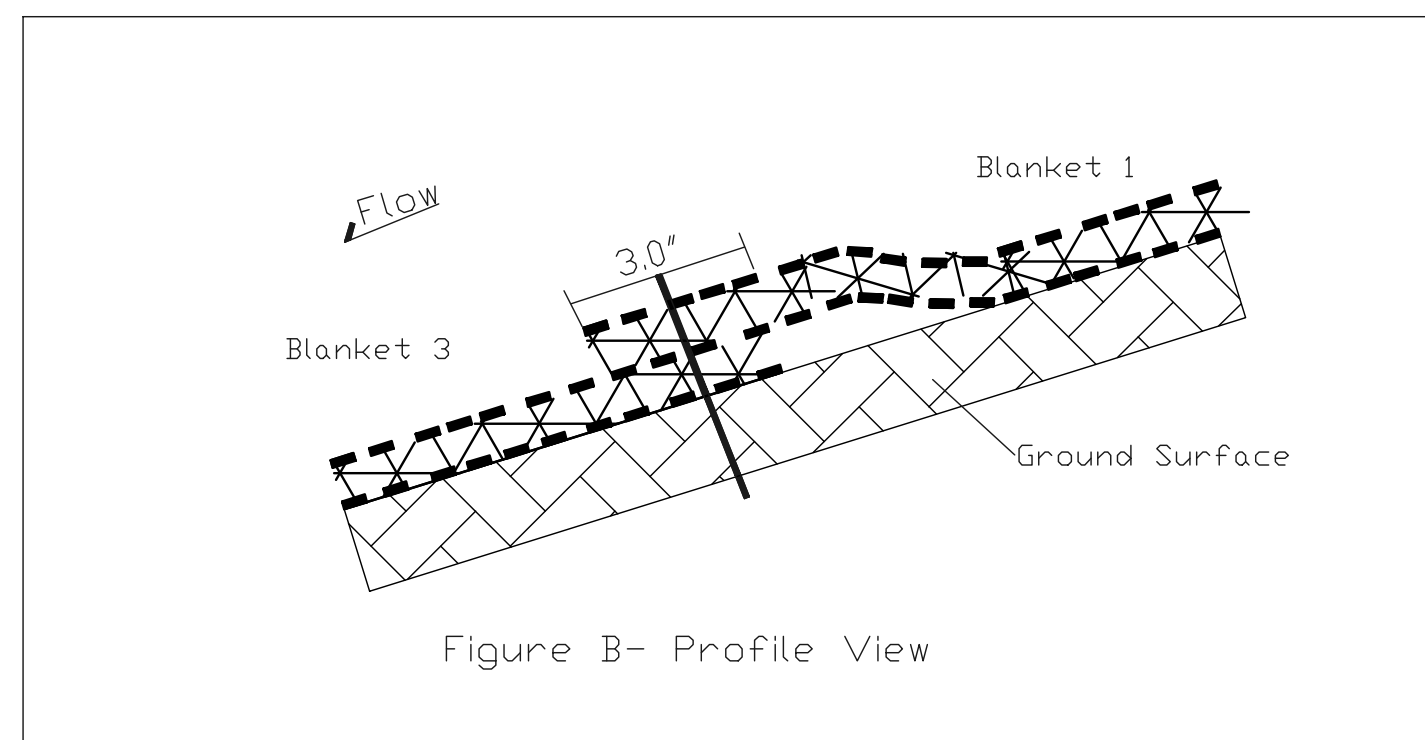

Figure B- Profile View

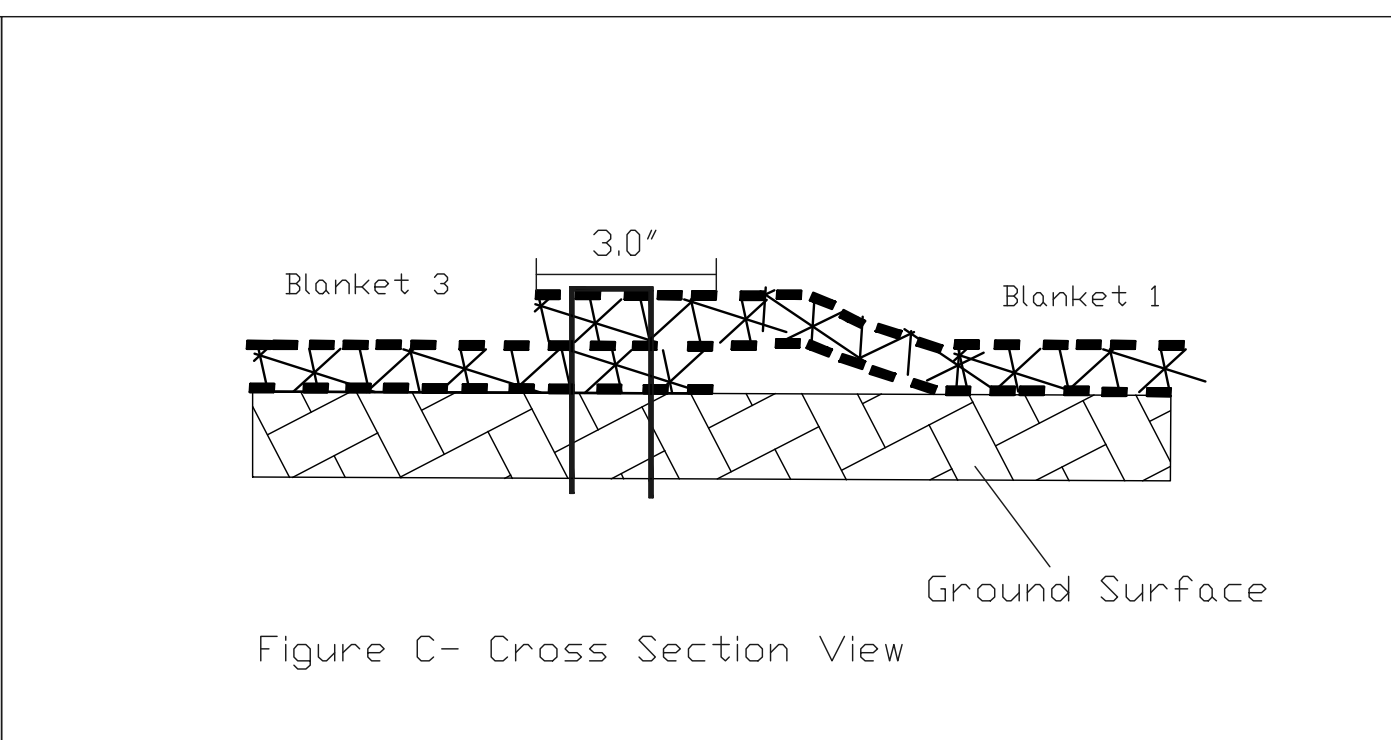

Figure C- Cross Section View

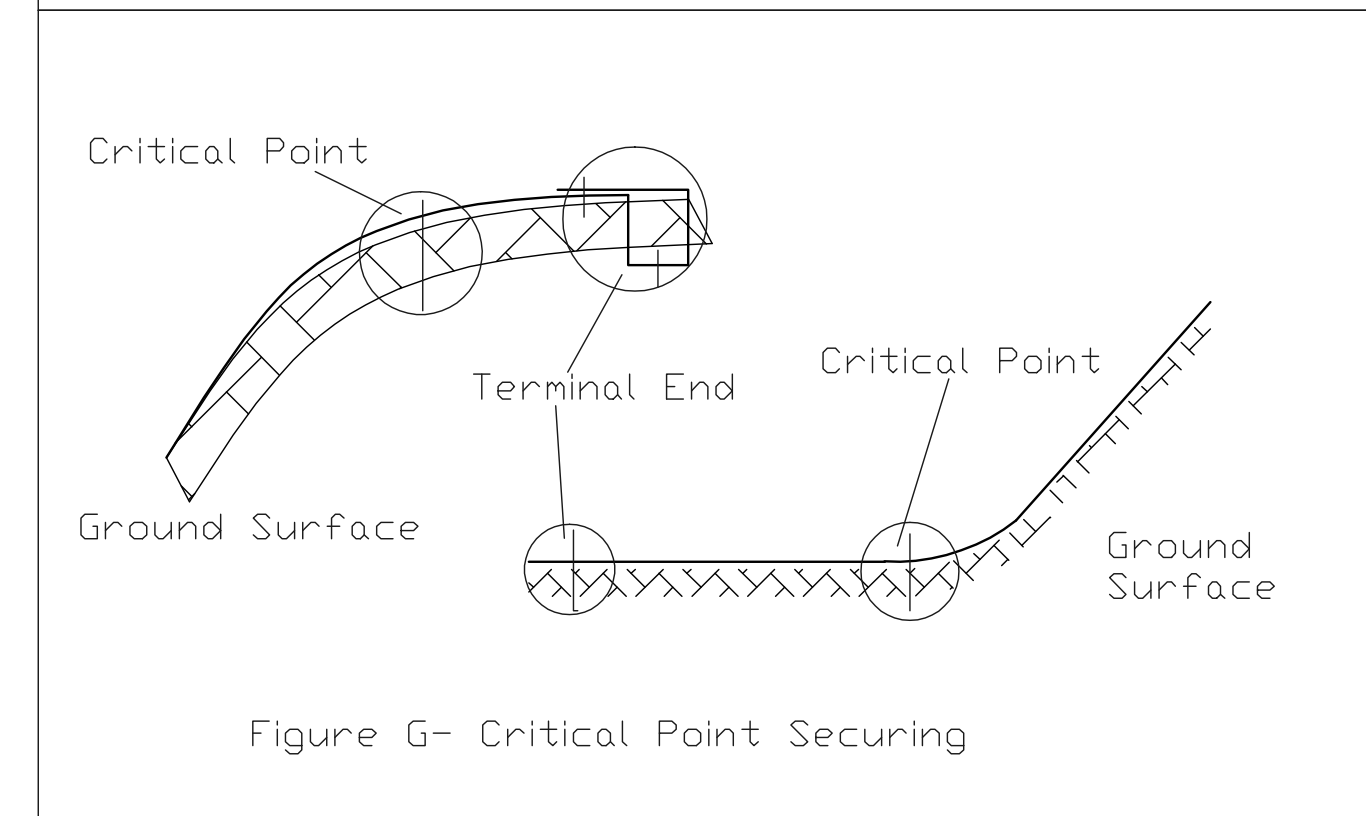

Figure G- Critical Point Securing

1
D-3 EROSION CONTROL BLANKETS
NTS

General Notes

**TOWN OF VAIL
STEPHEN'S PARK BANK STABILIZATION
PRELIMINARY DESIGN
EROSION CONTROL BLANKETS**

NOT FOR CONSTRUCTION

No.	Revision/Issue	Date

Firm Name and Address

RIVER
RESTORATION.ORG
 P.O. Box 2123
 Glenwood Springs, CO 81602
 www.RiverRestoration.org

Project Name and Address
**TOWN OF VAIL
GORE CREEK**

Project	STEPHENS	Sheet	D-3
Date	06-29-2010		
Scale	NTS		

NOTE: STAKES SHOULD BE PLACED RANDOMLY AT A RATE OF 2 HOLES PER SQUARE YARD. INSTALL 3 LIVE STAKES (WHERE POSSIBLE) PER HOLE.

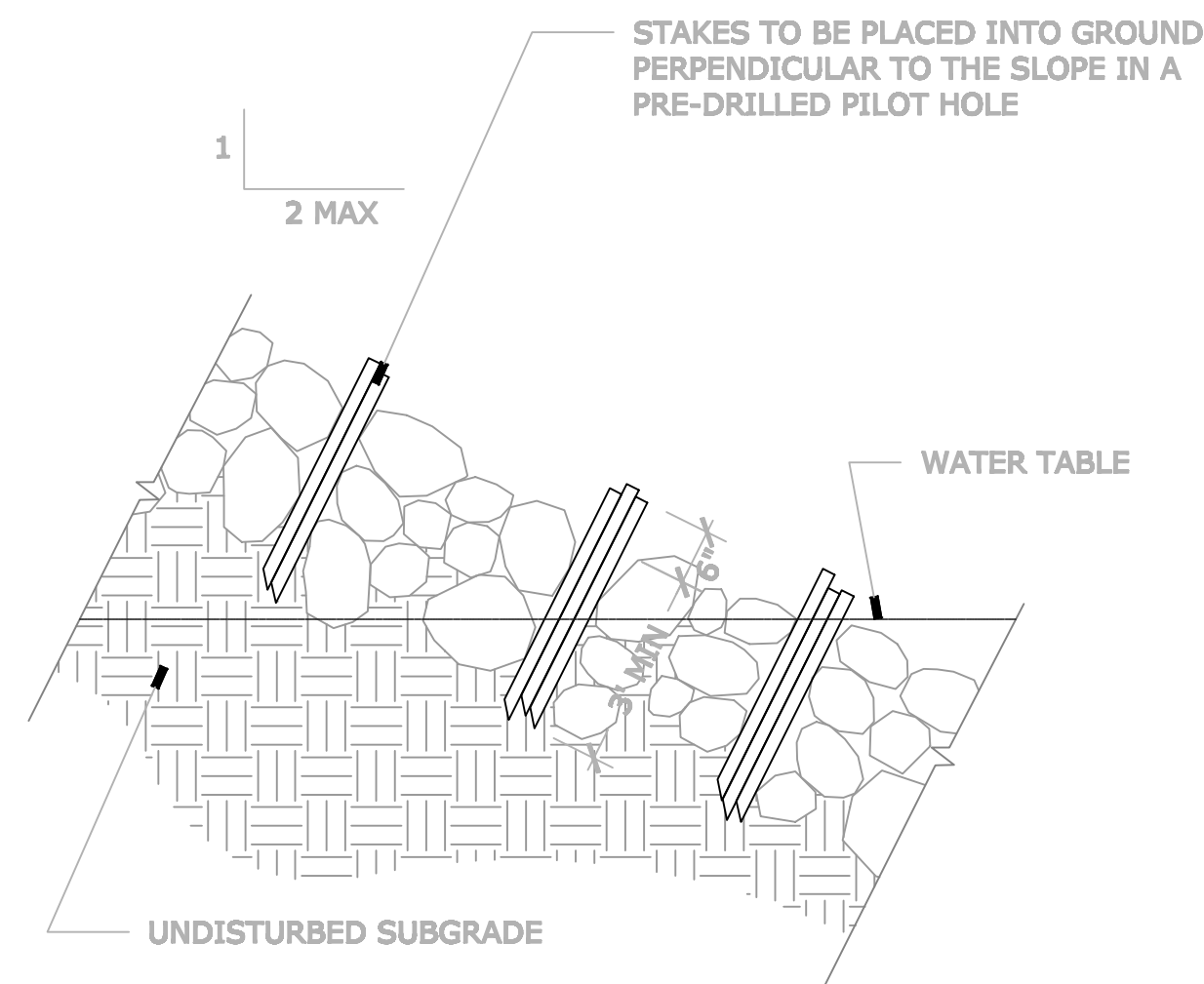

1 POLE STAKING
D-4 NTS

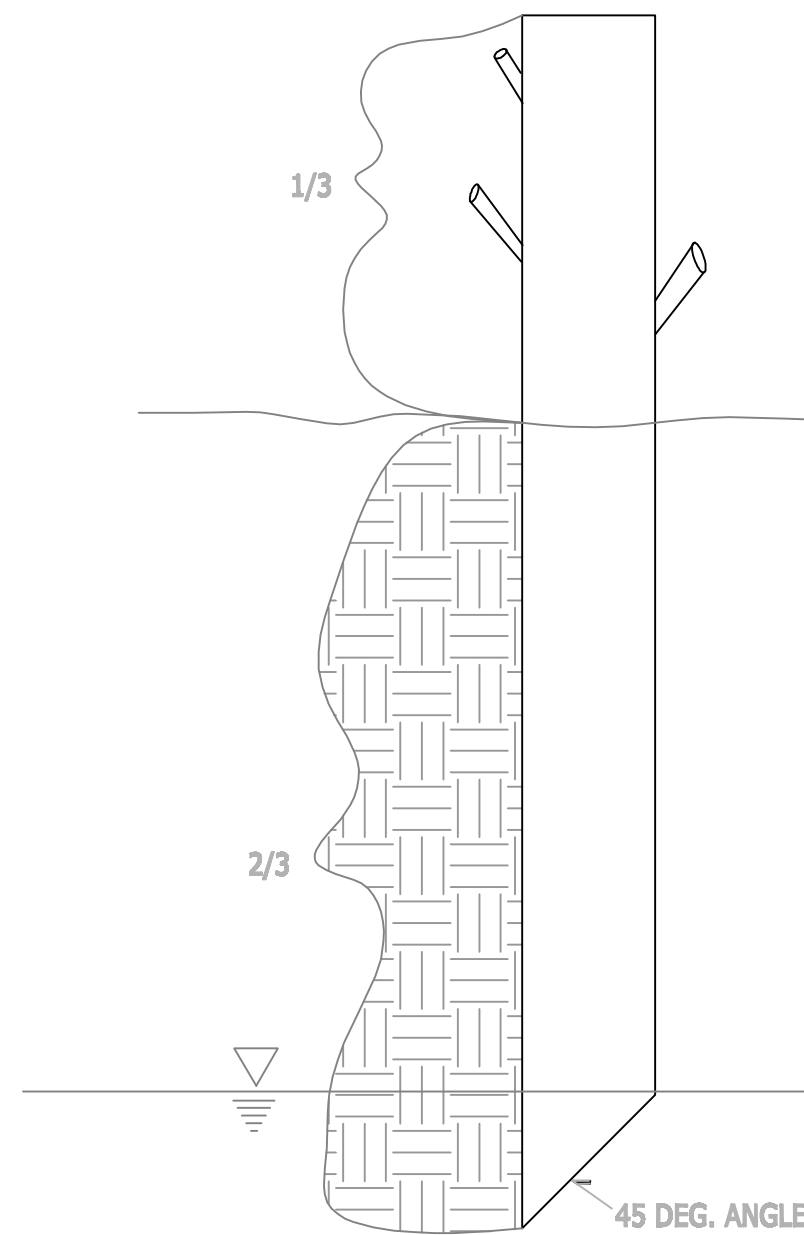

1. SEE SPECIFICATIONS
2. CUTTINGS SHALL BE COLLECTED WHILE DORMANT, WHEN THE LEAVES HAVE FALLEN, AND NIGHT TEMPERATURES ARE FREEZING.
3. CUTTINGS OF WILLOWS SHALL BE 0.75"-1.5" IN DIAMETER, AND 3-6' IN LENGTH. COTTONWOOD CUTTINGS SHALL BE 2"-3" IN DIAMETER, AND 6' MINIMUM IN LENGTH.
4. CUTTING SHALL BE TAKEN FROM THE BASE OF THE STEMS. CUT THE BOTTOMS AT A 45 DEG. ANGLE AND THE TOPS FLAT.
5. CUTTINGS SHALL BE STRIPPED OF LEADERS, AND LONG BRANCHES TO AVOID EXCESS DRYING.
6. CUTTINGS SHOULD BE STORED IN WATER AND SHADE FOR UP TO 24 HOURS BEFORE PLANTING.
7. PLANT THE CUTTINGS WITH THEIR BASES AT OR NEAR THE 200 CFS WATER ELEVATION.
8. LIGHTLY PAINT THE EXPOSED CUTS OF THE COTTONWOOD POLES WITH 50/50 MIX OF LATEX PAINT AND WATER TO REDUCE WATER LOSS.

2 STAKE/TREE POLE PLANTING
D-4 NTS

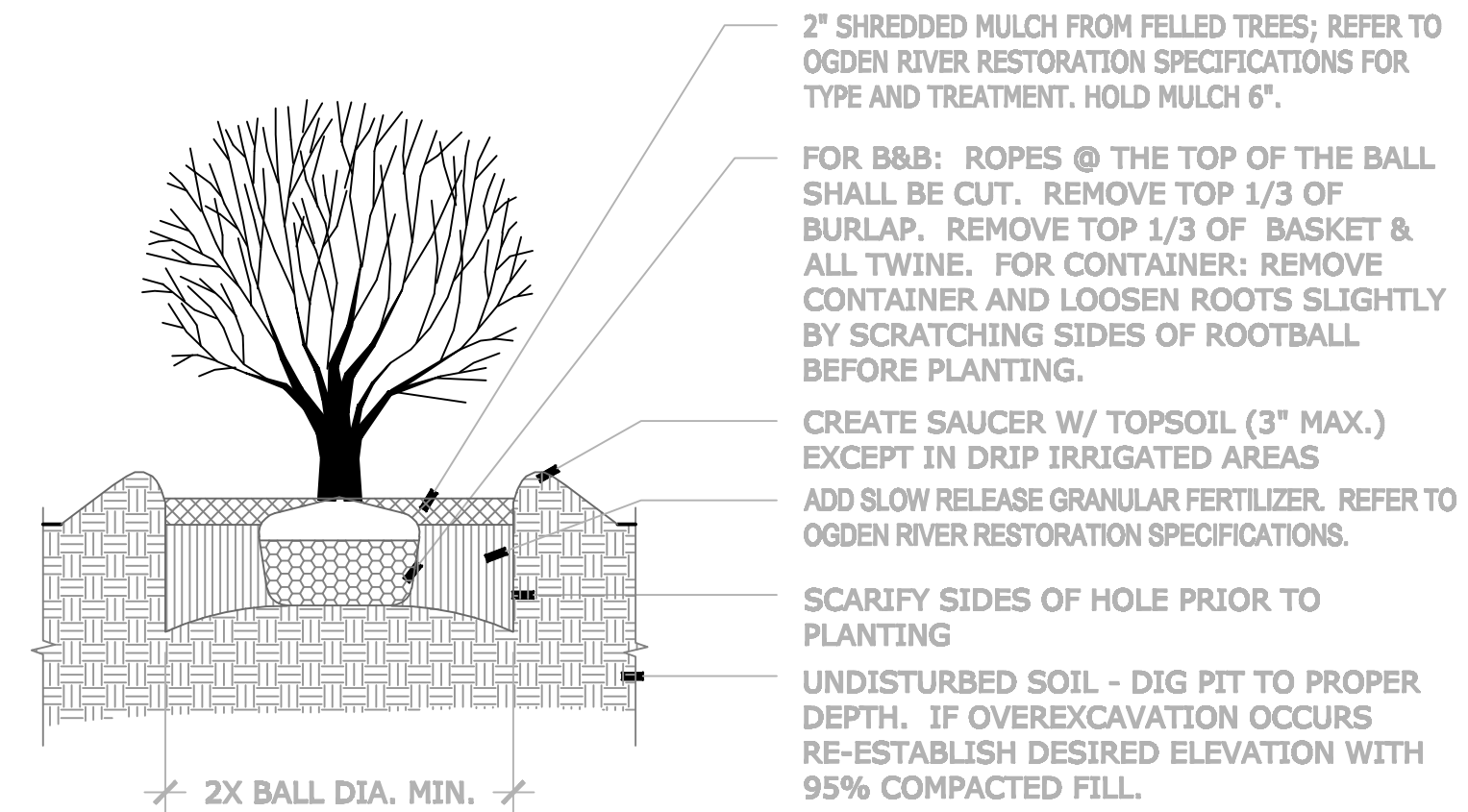

3 SHRUB PLANTING
D-4 NTS

Pitkin County Whitewater Park Plant List

Transitional Seed Mix

species	common name	percent	notes
Dechampsia caespitosa	Tufted Hairgrass vns	10	Seed should be planted into straw mat at a rate of 32 lb PLS/ac through broadcast seeding
Elymus lanceolatus ssp. lanceolatus	Thickspike Wheatgrass 'Critana'	15	
Elymus lanceolatus ssp. psammophilus	Streambank Wheatgrass 'Sodar'	20	
Elytrigia intermedia ssp. intermedia	Slender Wheatgrass 'San Luis'	10	
Pascopyron smithii	Western Wheatgrass 'Arriba'	35	
Poa palustris	Fowl Bluegrass vns	10	

Trees and Shrubs

species	common name	quantity	size	spacing
Acer negundo 'Sensation'	Sensation Boxelder	12	2.5" B&B	35' o.c.
Betula occidentalis	Western River Birch	7	5'	15-20' o.c.

Riparian Shrubs

species	common name	percent	quantity	size	spacing
Salix exigua	Coyote Willow	70	177	#5	6' o.c.
Salix lutea	Yellow Willow	30	22	#5	10' o.c.

**TOWN OF VAIL
STEPHEN'S PARK BANK STABILIZATION
PRELIMINARY DESIGN
PLANT INSTALLATION**

NOT FOR CONSTRUCTION

No.	Revision/Issue	Date

Firm Name and Address



RIVER
RESTORATION.ORG
P.O. Box 2123
Glenwood Springs, CO 81602
www.RiverRestoration.org

Project Name and Address

**TOWN OF VAIL
GORE CREEK**

Project	STEPHENS	Sheet	D-4
Date	06-29-2010	Scale	
Scale	NTS		



PO Box 02123, Glenwood Springs, Colorado 81602. (970) 947-9568

July 12, 2010

Mr. Tom Kassmel
Town of Vail
75 S. Frontage Road,
Vail, CO 81657
(970) 479-2235

RE: Stephens Park Bank Stabilization, Floodplain Compliance

Dear Tom,

Proposed bank stabilization at Stephens Park includes in-channel modifications to hydraulics for concentrated access. This letter is to discuss how the proposed modifications comply with Town of Vail and Federal floodplain development guidelines.

TOV: 12-21-10: DEVELOPMENT RESTRICTED: (E) The Administrator may require any applicant or person desiring to modify the flood plain by fill, construction, channelization, grading, or other similar changes, to submit for review an environmental impact statement in accordance with Chapter 12 of this Title, to establish that the work will not adversely affect adjacent properties, or increase the quantity or velocity of flood waters. (Ord. 16(1983) § 1: Ord. 12(1978) § 4)

Existing Conditions

A floodplain model in HEC-RAS format was obtained from Town of Vail. Three geometry profiles were developed; Duplicate Effective, Existing and Proposed Conditions. The Duplicate Effective is the imported geometry titled "Imported Geo01mbjrevised"; which is the most current FEMA flood model for Gore Creek at the Stephens Park reach. The Existing Conditions model is the Duplicate Effective with the insertion of seven additional cross sections surveyed by RiverRestoration in the Fall of 2009. The Proposed Conditions model is the Existing Conditions model with cross sections modified to represent worst case scenario channel changes and analyze hydraulics of the proposed conditions.

No hydrologic analysis was performed; flood flows were based on the Federal Insurance Study reported values. The 100year discharge is 2620cfs through the Project reach. This flow was likely exceeded on June 6, 2010 and water surface elevations crested 7854.5 feet elevation near river station 11+00. Additional bank erosion occurred as a result of this event.

The existing FEMA model does not specifically represent flood conditions at the project area. FEMA cross sections are located 150 feet upstream or 350 feet downstream of the



PO Box 02123, Glenwood Springs, Colorado 81602. (970) 947-9568

proposed work. The discrepancy between the Duplicate Effective and Existing conditions model is the resolution of channel geometry of the reach. The geometry in the FEMA model is based from aerial and ground topography over long distances. The geometry in the Existing conditions model is based from site-specific channel geometry surveyed by RiverRestoration Fall 2009. The Existing conditions model shows greater detail of channel geometry and a more accurate representation of flood flow conveyance. The Existing conditions base flood elevations are predicted slightly lower than effective values interpolated between River Station (RS) 1298.6 and 643.1.

The Proposed Conditions model increases the backwater effect over existing conditions but remains below the interpolated values of the effective model. All predicted water surface elevation changes are absorbed in the steep channelized section upstream of RS 1298.6. The Proposed Conditions do not adversely affect adjacent properties, or increase the quantity or velocity of flood waters appreciably over effective values published by FEMA. This is because of the steep banks and steep channel. Zone X, Floodplain and the Floodway are coincident here. Although Proposed base flood elevations are higher than Existing conditions, the flood waters will remain within the Effective floodway delineation and not overtop the existing river banks. The floodway and 100 year floodplain delineation lines are not appreciably moved. Table 1 compares the Effective base flood elevation with the Duplicate, Existing and Proposed condition hydraulic models.

Please contact me with any questions or comments.

Sincerely,

Jason Carey P.E.
River Engineer
jason.carey@riverrestoration.org
(970) 947-9568

cc. Gregg Barrie, Kristen Bertuglia



PO Box 02123, Glenwood Springs, Colorado 81602. (970) 947-9568

Table 1 Base Flood Elevations for Stephens Park Reach (2620cfs) 07/12/10

River Station	Effective	Duplicate	Existing	Change	Alternative 2	Change
2126.81	7877.7	7877.83	7877.83	0	7877.83	0
1832.98		7872.04	7872.04	0	7872.04	0
1314			7858.99		7858.99	0
1298.7	7859.1	7858.99	7858.81	-0.18	7858.8	-0.01
1251		7858.23	7856.97	-1.26	7856.98	0.01
1172.5		7856.99	7855.43	-1.56	7855.43	0
1140		7856.47	7854.64	-1.83	7854.79	0.15
1100		7855.83	7854.41	-1.42	7854.94	0.53
1043		7854.93	7853.99	-0.94	7854.13	0.14
800		7851.07	7851.21	0.14	7851.21	0
643.1		7848.58	7848.58	0	7848.58	0
576.1		7847.76	7847.76	0	7847.76	0
564.2	Stephens Park Bridge					0
564.1		7846.86	7846.86	0	7846.86	0
516.5		7845.23	7845.23	0	7845.23	0
74.1	7840	7838.17	7838.17	0	7838.17	0
1		7836.14	7836.14	0	7836.14	0
-1	Kinnickinnick Bridge					0
-30		7835.92	7835.92	0	7835.92	0
-84.8		7836.35	7836.35	0	7836.35	0
-247.3		7834.72	7834.72	0	7834.72	0

INTERPOLATED VALUES

Red-tailed Hawk

Willow Riparian Habitat

What is a Riparian Zone?

A riparian zone is the land and vegetation along the banks of a creek, stream, or river. This interface provides critical functions related to habitat and water quality. In undeveloped mountain areas, the riparian zone can span the valley floor and consists of beaver ponds, stream channels and wetland vegetation. In developed areas such as Vail, these fragile and important ecosystems are typically narrow and follow the stream channel. They have evolved as a unique combination of water, soils and vegetation.

Why is the riparian zone important?

Habitat

The riparian zone along Gore Creek is one of the richest, most diverse habitats in Vail. The many plants, birds, insects and fish pictured here are dependent on this habitat. The typically dense vegetation provides cover, shelter and food for animals and insects to live and reproduce.

Water Quality

Riparian areas play a key role in protecting and improving water quality. The meandering bends of the channel, in combination with vegetated stream banks, slows stream flows and dissipates stream energy reducing erosion and flood damage. The riparian border filters stormwater runoff of sediment and contaminants.

Canopy and Shade

Gore Creek is a high altitude, cold water, Gold Medal Trout fishery that can be damaged by higher temperatures that reduce oxygen levels. Shading created by riparian vegetation keeps temperatures cool and provides cover from predators.

Native fauna

Native fauna benefit from a healthy riparian border as a food source and as cover from predators. Riparian zones increase biodiversity by providing corridors for wildlife and aquatic organisms to move along river systems, avoiding isolated communities.

Gold Medal Fishery

Gore Creek provides numerous recreational opportunities. Its Gold Medal waters are dependent upon a healthy riparian and aquatic ecosystem.

Aquatic Invertebrates

Aquatic invertebrates are an important indicator of stream health. These insects require clear, cool water and stable flows. Their reproductive cycles are dependant upon a healthy riparian border, and they are primary element in the aquatic food chain.

Riparian Vegetation

Riparian and aquatic plants stabilize the stream bank, filter sediment, and provide food, cover and reproductive habitat for a variety of birds, insects and other animals.

Stephens Park

Bank Stabilization Project

Years of heavy use and erosion resulted in a highly degraded stream bank here in Stephens Park. In 2010, the bank was stabilized and planted with native plant species to establish a healthy riparian zone.

Keep Gore Creek healthy by utilizing the designated access points and keeping children and pets off of the riparian plants. Remember that maintaining natural vegetation on the banks of river property is the best way to maintain a healthy habitat.

The Stephens Park Bank Stabilization Project was completed with the support of:

- The Colorado Water Conservation Board
- The Healthy Rivers Fund
- The Town of Vail

Pine Marten

Black Bear

Elk

Mule Deer

Mallards

Stonefly

Mayfly

Caddisfly

Magpie

Beaver

Red Fox

Currant

Raspberries

Mink

Rainbow Trout

Brown Trout

Cutthroat Trout

Blue Flag Iris

Sedge

Scarlet Gilla

Dipper

Monkey Flower

Columbine

Mariposa Lily

Fleabane

Horsetail

Hummingbird

Charmayne Thevet Berchardt



The cover features a vibrant green background with a repeating pattern of hexagons and vertical lines. A white rectangular area on the right side contains the title and subtitle. At the top of this white area is a solid dark grey rectangle. A thin green horizontal line is positioned at the bottom of the white area.

Stephens Park, Vail CO

Stream Bank Restoration
Project Photo Album

2011

Stephens Park - Before



Eroded bank, sediment building, no vegetation



Stephens Park – Construction Process









Volunteer Planting

